

PART REV	DWG ISSUE	DATE	ECN NO.	APPVD BY	REL BY
-	-	12-21-11	UMI 4533		

1	BLK
2	BRN
3	RED
4	ORG
5	YEL
6	GRN
7	BLU
8	VIO
9	GRY
10	WHT
11	W/BLK
12	W/BRN
13	W/RED
14	W/ORG
15	W/YEL
16	W/GRN
17	W/BLU
18	W/VIO
19	W/GRY
20	W/BLK/BRN
21	W/BLK/RED
22	W/BLK/ORG
23	W/BLK/YEL
24	W/BLK/GRN
25	W/BLK/BLU
26	W/BLK/VIO
27	W/BLK/GRY
28	W/BRN/RED
29	W/BRN/ORG
30	W/BRN/YEL
31	W/BRN/GRN
32	W/BRN/BLU
33	W/BRN/VIO
34	W/BRN/GRY
35	W/RED/ORG
36	W/RED/YEL
37	W/RED/GRN

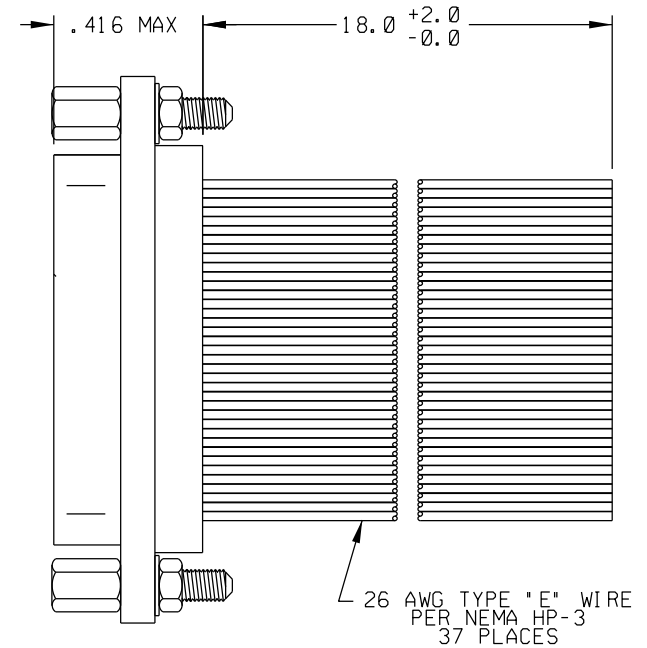
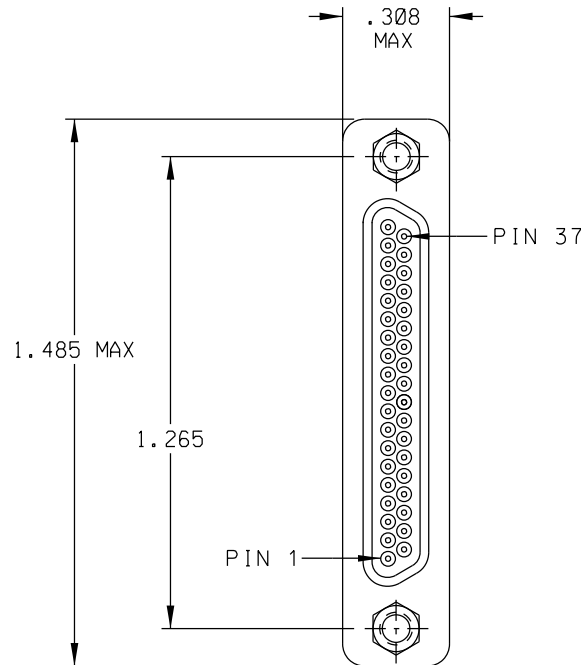

- 2 MATERIALS:  
 SHELL: 6061-T6 ALUMINUM PER AMS-QQ-A200/8, CAD PLATED PER AMS QQ-P-416  
 INSULATOR: PPS PER MIL-M-24519 GST-40F  
 PIN CONTACTS: C17200 BERYLLIUM COPPER PER ASTM-B194, GOLD PLATED PER ASTM B488  
 HARDWARE: PASSIVATED STAINLESS STEEL IAW MIL-DTL-83513/5

1. MARKING: UMI, DATE CODE, UMI P/N.  
 NOTES: UNLESS OTHERWISE SPECIFIED.

QUALITY SYMBOLS	UNLESS SPECIFIED: ALL DIMENSIONS IN INCHES	SCALE NONE	DWG SIZE B	THIRD ANGLE PROJECTION	REVISE ON CAD ONLY
MAJOR	GENERAL TOLERANCES: 3 PLACE ±.005 2 PLACE ±.01 ANGULAR ±2°	DRAWN BY & DATE DW 12-21-11	TITLE: MICRO-D PLUG, 37 POS., 18" 26 AWG TYPE "E" WIRE, MR37P07-26E5-18.0		
CRITICAL		CHECKED BY & DATE	MATERIAL: 2		
SPC	Uti-Mate CAGE CODE <b>58967</b>	APPROVED BY & DATE	CAD FILENAME SD-834160077.DGN	PART NO. 834160077	DRAWING NO. SD-834160077
S					SHEET NO. 1 OF 1
			THIS DRAWING CONTAINS INFORMATION THAT IS PROPRIETARY TO ULTI-MATE INCORPORATED AND SHOULD NOT BE USED WITHOUT WRITTEN PERMISSION.		
					REV -

Uti-Mate  
Connector Inc.