

10

9

8

7

6

5

4

3

2

SD-837042483

PART REV	DWG ISSUE	DATE	ECN NO.	APPVD BY	REL BY
-	-	9/24/18	UMI6879	DW	DW

F

E

D

C

B

A

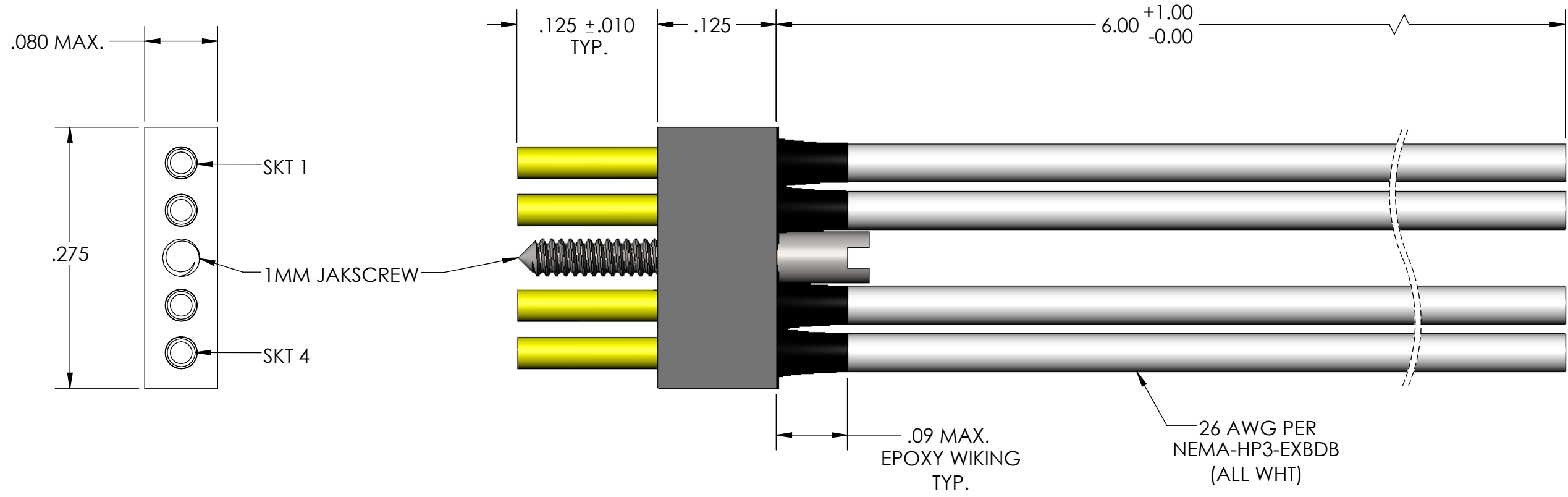

- 4. CONTACT HEIGHTS ARE TO BE PER QA-STD-101.
- 3. PERFORMANCE SPECIFICATIONS:
CURRENT RATING: 3 AMPS MAX.
DWV: 600 VAC
TEMPERATURE RATING: -55 °C TO 125 °C

- 2. MATERIALS:
STRIP INSULATOR: PPS PER MIL-M-24519 GST-40F, COLOR: BLACK
SOCKET CONTACTS: C21000 COPPER ALLOY PER ASTM B36, GOLD PLATED PER ASTM-B488
HARDWARE: PASSIVATED STAINLESS STEEL, 300 SERIES
WIRES: 26 AWG PER NEMA-HP3-EXBDB, COLOR CODE: ALL WHITE

1. BAG AND TAG WITH "UMI", DATE CODE, UMI PART NUMBER, UMI WORK ORDER NUMBER

NOTES: UNLESS OTHERWISE SPECIFIED.

QUALITY SYMBOLS CRITICAL MAJOR NO SYMBOLS = MINOR DIMENSIONS	UNLESS OTHERWISE SPECIFIED; ALL DIMENSIONS ARE IN INCHES	SCALE 8:1	DWG SIZE B	THIRD ANGLE PROJECTION	REVISE ON CAD ONLY
	GENERAL TOLERANCES: 3 PLACES ±.005 2 PLACES ±.01 ANGULAR ±2°	DRAWN BY & DATE DU 9/24/18	TITLE: MICRO STRIP CONNECTOR, SR04S3-26E1-6.0		
	ULTI-MATE CAGE CODE 58967	CHECKED BY & DATE DW 9/24/18	MATERIAL: 3	ENG PROJECT #: NONE	
		APPROVED BY & DATE DW 9/24/18	PART NO. 837042483	DRAWING NO. SD-837042483	
		CAD FILE NAME SD-837042483.SLDDRW		THIS DRAWING CONTAINS INFORMATION THAT IS PROPRIETARY TO ULTI-MATE INCORPORATED AND SHOULD NOT BE USED WITHOUT WRITTEN PERMISSION.	
				PART REV. -	