

PART REV	DWG ISSUE	DATE	ECN NO.	APPVD BY	REL BY
-	-	5/8/18	UMI6763	DW	DW

F  
E  
D  
C  
B  
A

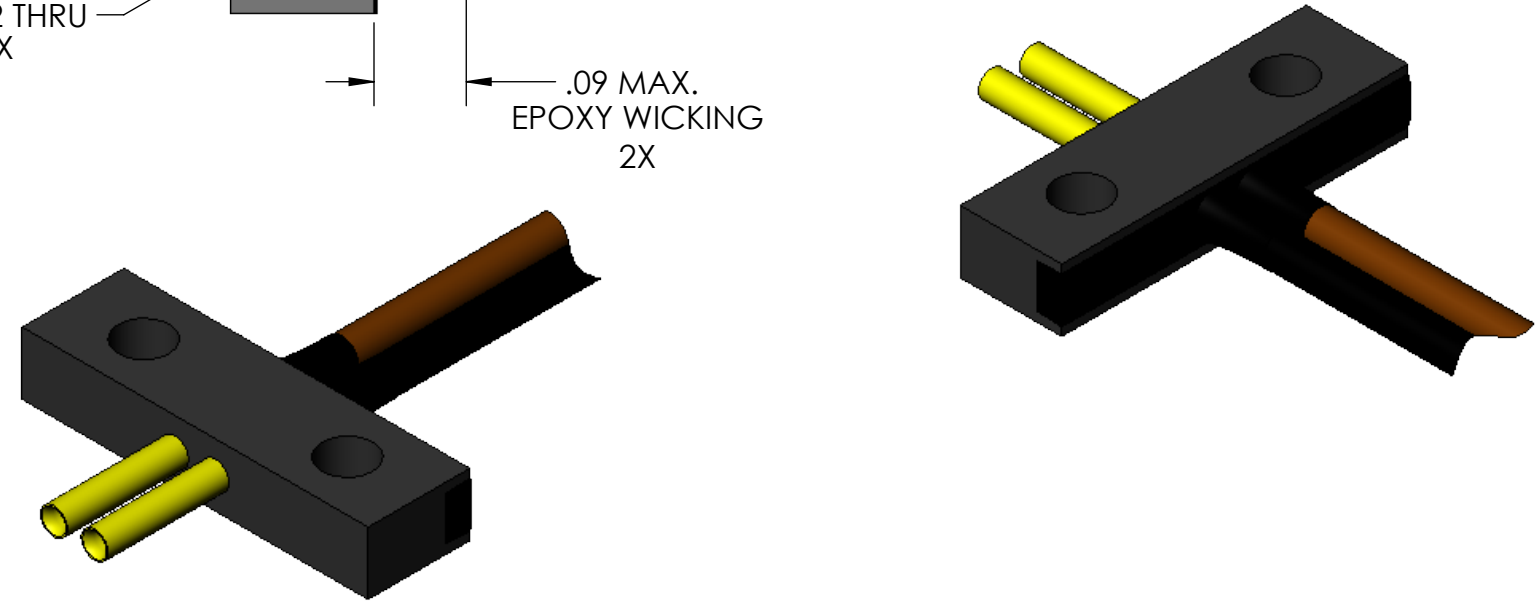
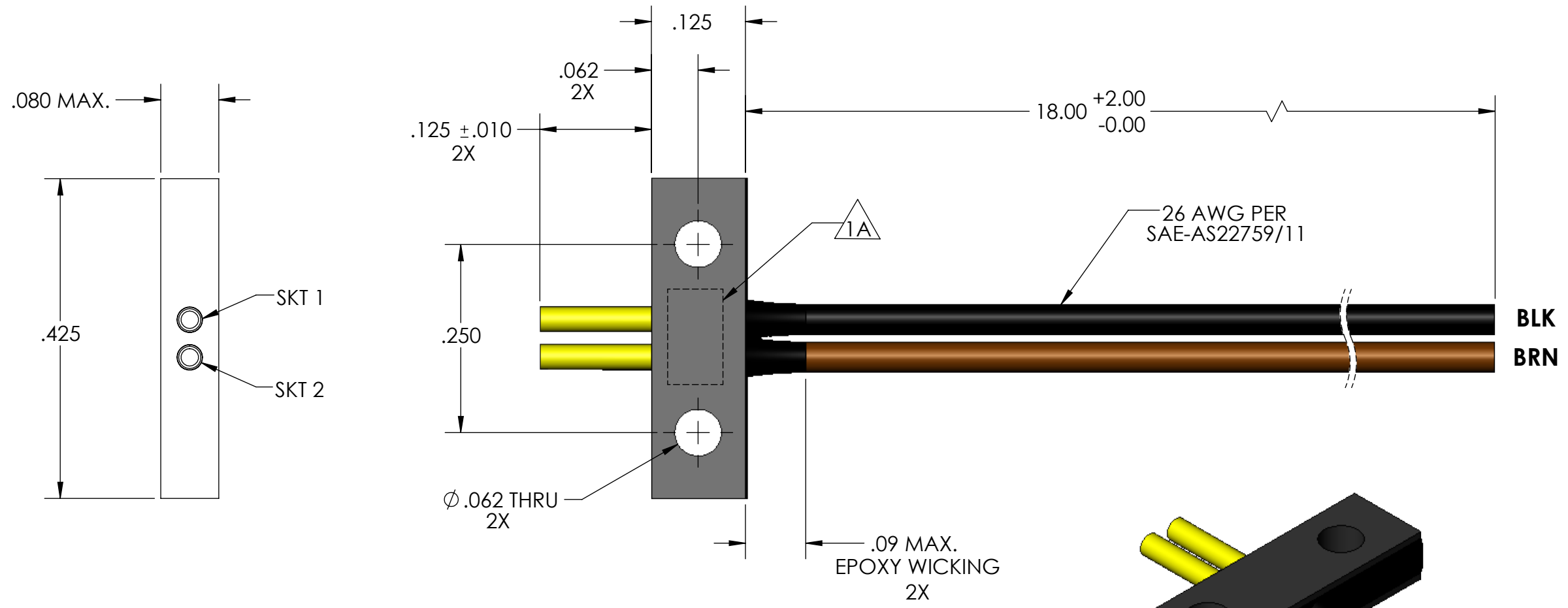

- 4. CONTACT HEIGHTS ARE TO BE PER QA-STD-101.
- 3. PERFORMANCE SPECIFICATIONS:  
CURRENT RATING: 3 AMPS MAX.  
DWV: 600 VAC  
TEMPERATURE RATING: 125° C

2 MATERIALS:  
INSULATOR: PPS PER MIL-M-24519 GST-40F, COLOR: BLACK  
SOCKET CONTACTS: C21000 COPPER ALLOY PER ASTM B36, GOLD PLATED PER ASTM-B488  
WIRE: 26 AWG PER SAE-AS22759/11, COLOR CODE: PER MIL-STD-681

1. MARKING:

1A DATE CODE

1B. BAG AND TAG WITH "UMI", DATE CODE, UMI PART NUMBER, UMI WORKORDER NUMBER

NOTES: UNLESS OTHERWISE SPECIFIED.

QUALITY SYMBOLS CRITICAL MAJOR NO SYMBOLS = MINOR DIMENSIONS	UNLESS OTHERWISE SPECIFIED: ALL DIMENSIONS ARE IN INCHES	SCALE 6:1	DWG SIZE B	THIRD ANGLE PROJECTION	REVISE ON CAD ONLY		
	GENERAL TOLERANCES:  3 PLACES ±.005 2 PLACES ±.01 ANGULAR ±2°	DRAWN BY & DATE DU 4/30/18		TITLE: MICRO STRIP CONNECTOR, SR02S4-26M5-18.0			
		CHECKED BY & DATE DW 4/30/18		MATERIAL: 2	ENG PROJECT #: E374		
		APPROVED BY & DATE DW 4/30/18		PART NO. 837022064	DRAWING NO. SD-837022064	SHEET NO. 1 of 1	
	ULTI-MATE CAGE CODE 58967	CAD FILE NAME SD-837022064.SLDDRW	THIS DRAWING CONTAINS INFORMATION THAT IS PROPRIETARY TO ULTI-MATE INCORPORATED AND SHOULD NOT BE USED WITHOUT WRITTEN PERMISSION.				PART REV. -