

REVISIONS

PART REV.	DWG. ISSUE	DATE	ECN NO.	APPVD. BY	REL. BY
-	-	11/07/2013	UMI5151	DW	DW
A	A	12/21/2016	UMI6181	DW	DW

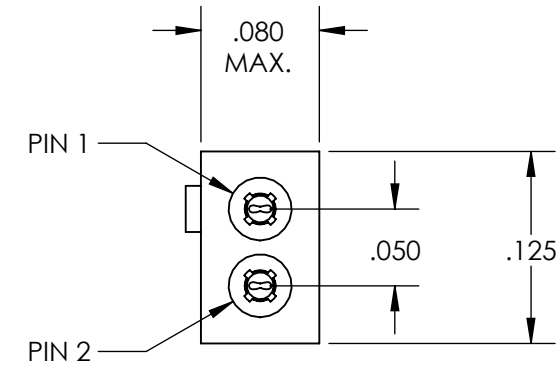
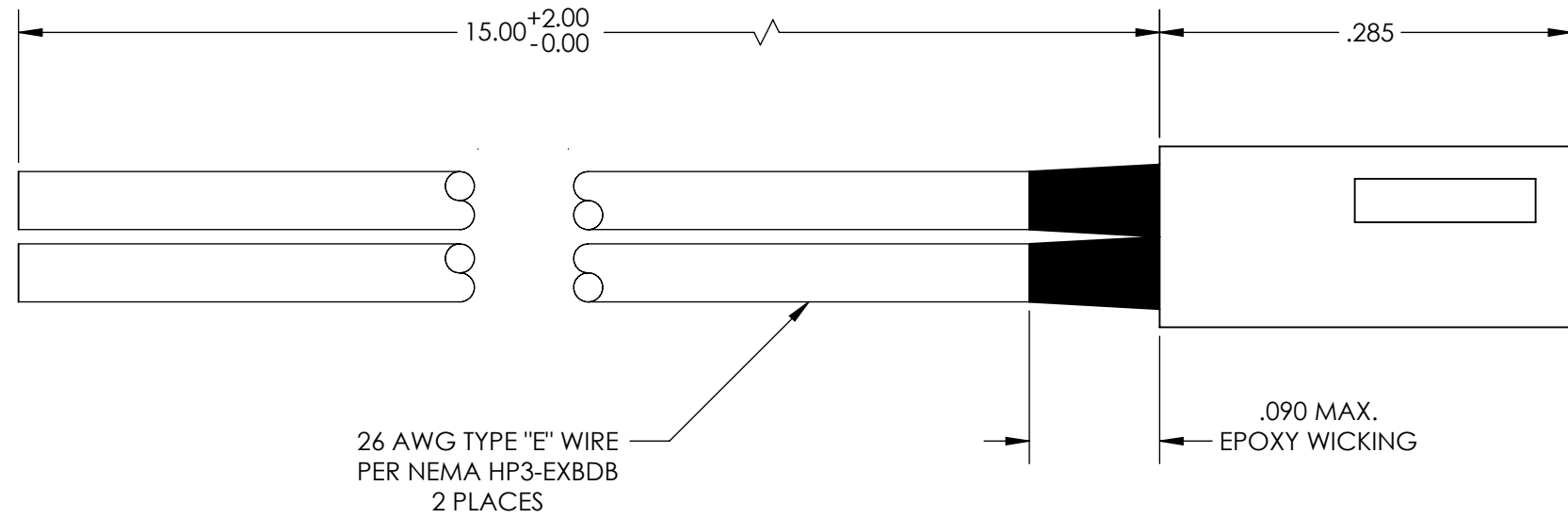

COLOR CODE

1	BLK
2	BRN

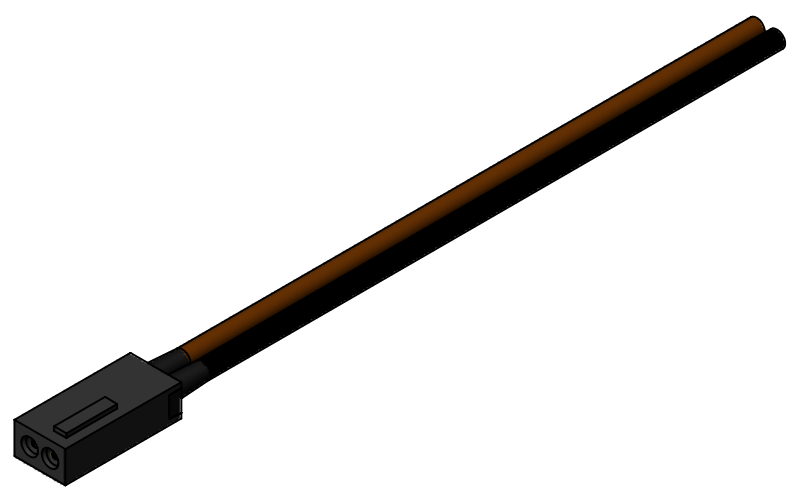

3. PERFORMANCE SPECIFICATIONS: (AT AMBIENT TEMPERATURE)
 CURRENT RATING: 3A MAX.
 INSULATION RESISTANCE: 5000 MΩ MIN.
 DWV: 600 VAC
 TEMPERATURE RATING: 125°C

2 MATERIALS:
 INSULATOR: PPS PER MIL-M-24519 GST-40F, COLOR: BLK
 PIN CONTACTS: C17200 BERYLLIUM COPPER PER ASTM B194, GOLD PLATED PER ASTM B488

1. MARKINGS: NONE
 NOTES: UNLESS OTHERWISE SPECIFIED

QUALITY SYMBOLS CRITICAL MAJOR NO SYMBOL = MINOR DIMENSION	UNLESS SPECIFIED: ALL DIMENSIONS IN INCHES GENERAL TOLERANCES: 3 PLACE ±.005 2 PLACE ±.01 ANGULAR ±2°	SCALE 8:1 DWG SIZE B	THIRD ANGLE PROJECTION	REVISE ON CAD ONLY		
	ALL EXTERNAL SPECIFICATIONS REFERENCED ON THIS DRAWING SHALL BE THE LATEST REVISION IN EFFECT	DRAWN BY & DATE JB 11/07/2013	TITLE MICRO STRIP WIRED CONNECTOR PLUG (PINS), 2 POSITION SR02P0-26E5-15.0			
	Ultri-Mate CAGE CODE 58967	CHECKED BY & DATE DW 11/12/2013	MATERIAL			
		APPROVED BY & DATE DW 11/12/2013	ENG PROJECT #			
		CAD FILENAME SD-837021290.slddrw	PART NO. 837021290	DRAWING NO. SD-837021290	SHEET NO. 1 OF 1	PART REV. A

THIS DRAWING CONTAINS INFORMATION THAT IS PROPRIETARY TO ULTI-MATE INCORPORATED AND SHOULD NOT BE USED WITHOUT WRITTEN PERMISSION.