

PART REV	DWG ISSUE	DATE	ECN NO.	APPVD BY	REL BY
-	-	2/14/18	UMI6657	DW	DW

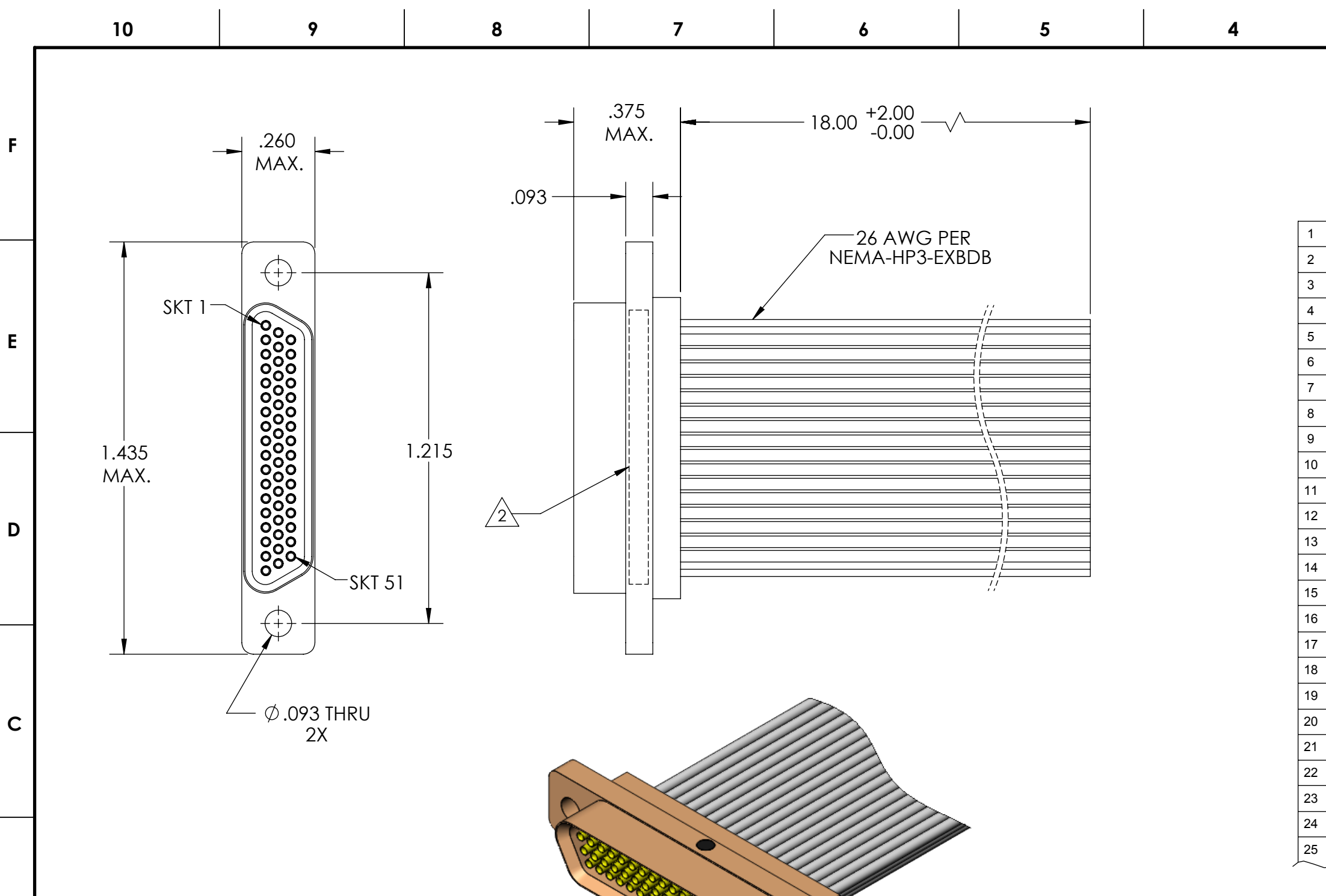

1	BLK	26	W/BLK/VIO
2	BRN	27	W/BLK/GRY
3	RED	28	W/BRN/RED
4	ORG	29	W/BRN/ORG
5	YEL	30	W/BRN/YEL
6	GRN	31	W/BRN/GRN
7	BLU	32	W/BRN/BLU
8	VIO	33	W/BRN/VIO
9	GRY	34	W/BRN/GRY
10	WHT	35	W/RED/ORG
11	W/BLK	36	W/RED/YEL
12	W/BRN	37	W/RED/GRN
13	W/RED	38	W/RED/BLU
14	W/ORG	39	W/RED/VIO
15	W/YEL	40	W/RED/GRY
16	W/GRN	41	W/ORG/YEL
17	W/BLU	42	W/ORG/GRN
18	W/VIO	43	W/ORG/BLU
19	W/GRY	44	W/ORG/VIO
20	W/BLK/BRN	45	W/ORG/GRY
21	W/BLK/RED	46	W/YEL/GRN
22	W/BLK/ORG	47	W/YEL/BLU
23	W/BLK/YEL	48	W/YEL/VIO
24	W/BLK/GRN	49	W/YEL/GRY
25	W/BLK/BLU	50	W/GRN/BLU
		51	W/GRN/VIO

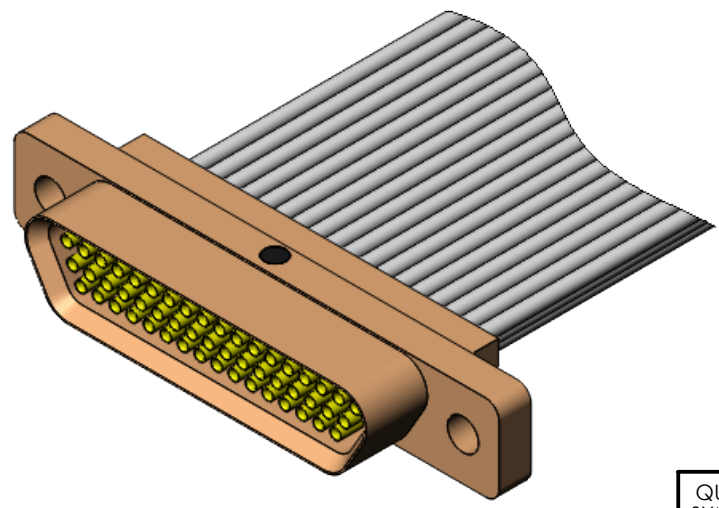

5. CONTACT HEIGHTS ARE TO BE PER QA-STD-101.
 4. PERFORMANCE SPECIFICATIONS:
 CURRENT RATING: 3 AMPS MAX.
 INSULATION RESISTANCE: 5000 MEGOHMS MIN.
 DWV: 600 VAC
 TEMPERATURE RATING: 125° C

3 MATERIALS:
 SHELL: 6061-T6 ALUMINUM PER AMS-Q-Q-A200/8, CADMIUM PLATED PER AMS-QQ-P-416
 INSULATOR: PPS PER MIL-M-24519 GST-40F, COLOR: BLACK
 SOCKET CONTACTS: C21000 COPPER ALLOY PER ASTM B36, GOLD PLATED PER ASTM B488
 WIRE: 26 AWG PER NEMA-HP3-EXBDB, COLOR CODE PER MIL-STD-681

2 MARKING: "UMI", DATE CODE, UMI PART NUMBER, UMI WORK ORDER NUMBER

1. CONNECTOR ASSEMBLY IS IAW MIL-DTL-83513 UNLESS OTHERWISE SPECIFIED.

NOTES: UNLESS OTHERWISE SPECIFIED.

QUALITY SYMBOLS CRITICAL MAJOR NO SYMBOLS = MINOR DIMENSIONS	UNLESS OTHERWISE SPECIFIED: ALL DIMENSIONS ARE IN INCHES	SCALE: NONE	DWG SIZE: B	THIRD ANGLE PROJECTION	REVISE ON CAD ONLY
	GENERAL TOLERANCES: 3 PLACES ±.005 2 PLACES ±.01 ANGULAR ±2°	DRAWN BY & DATE: DU 2/14/18		TITLE: MICRO-D LOW-PROFILE CONNECTOR ASSEMBLY, AR51-3S0-26E5-18.0	
	ULTI-MATE CAGE CODE: 58967	CHECKED BY & DATE: DW 2/14/18		MATERIAL: 3	ENG PROJECT #: NONE
		APPROVED BY & DATE: DW 2/14/18			
		CAD FILE NAME: SD-834470070.SLDDRW	PART NO.: 834470070	DRAWING NO.: SD-834470070	SHEET NO.: 1 of 1

THIS DRAWING CONTAINS INFORMATION THAT IS PROPRIETARY TO ULTI-MATE INCORPORATED AND SHOULD NOT BE USED WITHOUT WRITTEN PERMISSION.