

PART REV	DWG ISSUE	DATE	ECN NO.	APPVD BY	REL BY
-	-	3/16/15	UMI5548	DW	DW

F
E
D
C
B
A

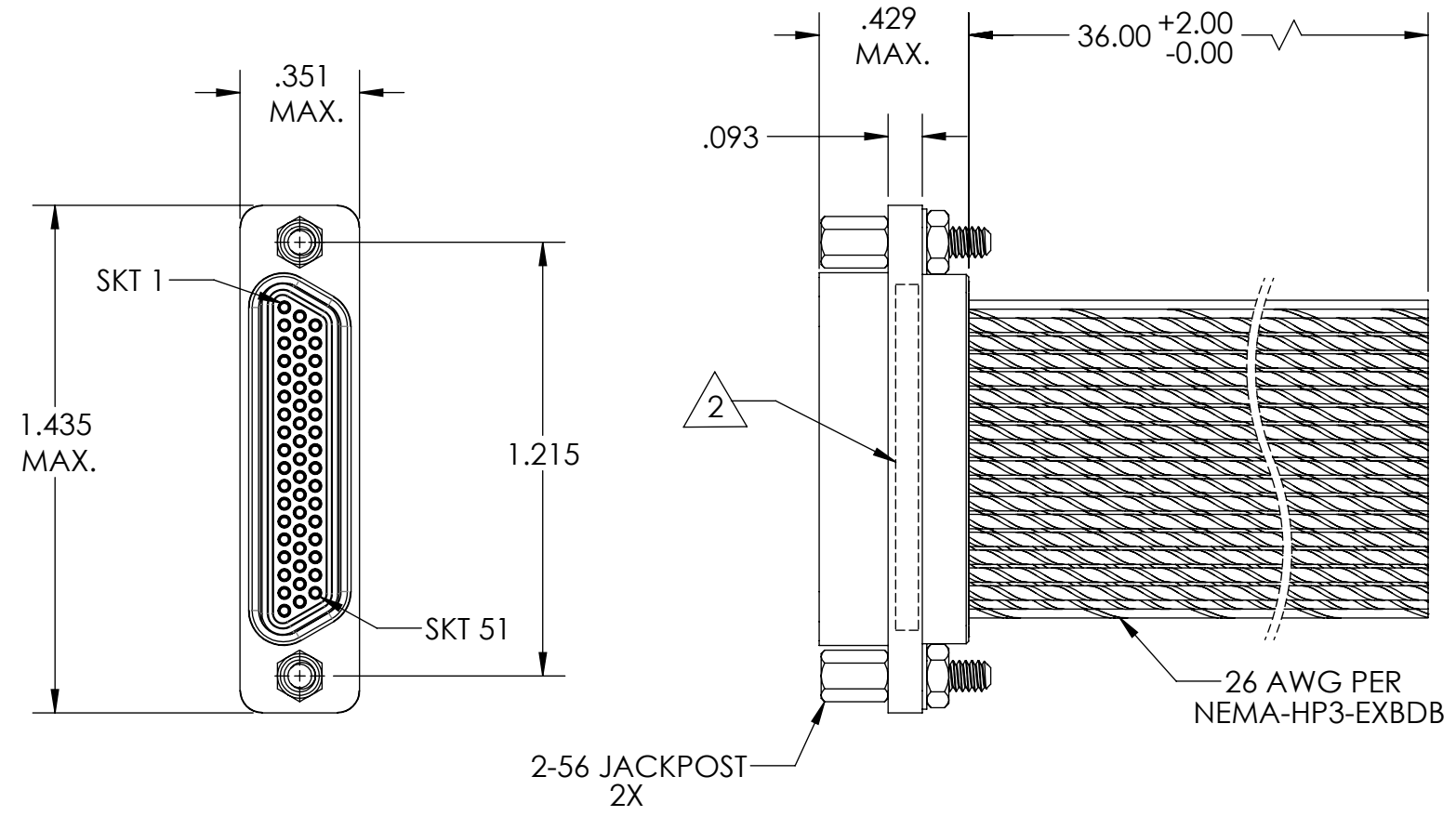

1	BLK	26	W/BLK/VIO
2	BRN	27	W/BLK/GRY
3	RED	28	W/BRN/RED
4	ORG	29	W/BRN/ORG
5	YEL	30	W/BRN/YEL
6	GRN	31	W/BRN/GRN
7	BLU	32	W/BRN/BLU
8	VIO	33	W/BRN/VIO
9	GRY	34	W/BRN/GRY
10	WHT	35	W/RED/ORG
11	W/BLK	36	W/RED/YEL
12	W/BRN	37	W/RED/GRN
13	W/RED	38	W/RED/BLU
14	W/ORG	39	W/RED/VIO
15	W/YEL	40	W/RED/GRY
16	W/GRN	41	W/ORG/YEL
17	W/BLU	42	W/ORG/GRN
18	W/VIO	43	W/ORG/BLU
19	W/GRY	44	W/ORG/VIO
20	W/BLK/BRN	45	W/ORG/GRY
21	W/BLK/RED	46	W/YEL/GRN
22	W/BLK/ORG	47	W/YEL/BLU
23	W/BLK/YEL	48	W/YEL/VIO
24	W/BLK/GRN	49	W/YEL/GRY
25	W/BLK/BLU	50	W/GRN/BLU
		51	W/GRN/VIO

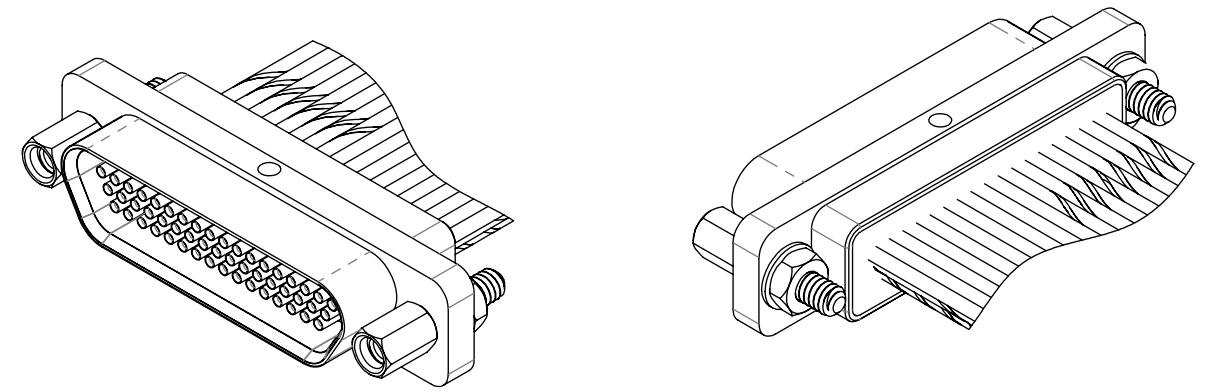

4. PERFORMANCE SPECIFICATIONS:
 CURRENT RATING: 3 AMPS MAX.
 INSULATION RESISTANCE: 5000 MEGOHMS MIN.
 DWV: 600 VAC
 TEMPERATURE RATING: 125° C

3 MATERIALS:
 SHELL: 6061-T6 ALUMINUM PER AMS-QQ-A200/8, CADMIUM PLATED PER AMS-QQ-416
 INSULATOR: PPS PER MIL-M-24519 GST-40F, COLOR: BLACK
 SOCKET CONTACT: C21000 COPPER ALLOY PER ASTM B36, GOLD PLATED PER ASTM B488
 WIRE: 26 AWG PER NEMA-HP3-EXBDB, COLOR CODE: PER MIL-STD-681
 HARDWARE: PASSIVATED STAINLESS STEEL IAW MIL-DTL-83513/5
 INTERFACIAL SEAL: FLUOROSILICONE PER MIL-R-25988

2 MARKING: "UMI", DATE CODE, UMI PART NUMBER
 1. CONNECTOR ASSEMBLY IS IAW MIL-DTL-83513 UNLESS OTHERWISE SPECIFIED.
NOTES: UNLESS OTHERWISE SPECIFIED.

QUALITY SYMBOLS CRITICAL MAJOR NO SYMBOLS = MINOR DIMENSIONS	UNLESS OTHERWISE SPECIFIED: ALL DIMENSIONS ARE IN INCHES	SCALE 2:1	DWG SIZE B	THIRD ANGLE PROJECTION	REVISE ON CAD ONLY	
	GENERAL TOLERANCES: 3 PLACES ±.005 2 PLACES ±.01 ANGULAR ±2°	DRAWN BY & DATE DU 3/16/15	TITLE: MICRO-D CONNECTOR ASSEMBLY, MR51-3S07-26E5-36.0		ENG PROJECT #: NONE	
	ULTI-MATE CAGE CODE 58967	CHECKED BY & DATE DW 3/16/15	MATERIAL: 3		SHEET NO. 1 of 1	
		APPROVED BY & DATE DW 3/16/15	CAD FILE NAME SD-834270537.SLDDRW	PART NO. 834270537	DRAWING NO. SD-834270537	PART REV. -

THIS DRAWING CONTAINS INFORMATION THAT IS PROPRIETARY TO ULTI-MATE INCORPORATED AND SHOULD NOT BE USED WITHOUT WRITTEN PERMISSION.

