

| PART REV | | DWG ISSUE | DATE | ECN NO. | APPVD BY | REL BY |
|----------|--|-----------|---------|---------|----------|--------|
| - | | - | 2/10/20 | UMI7390 | DU | DW |

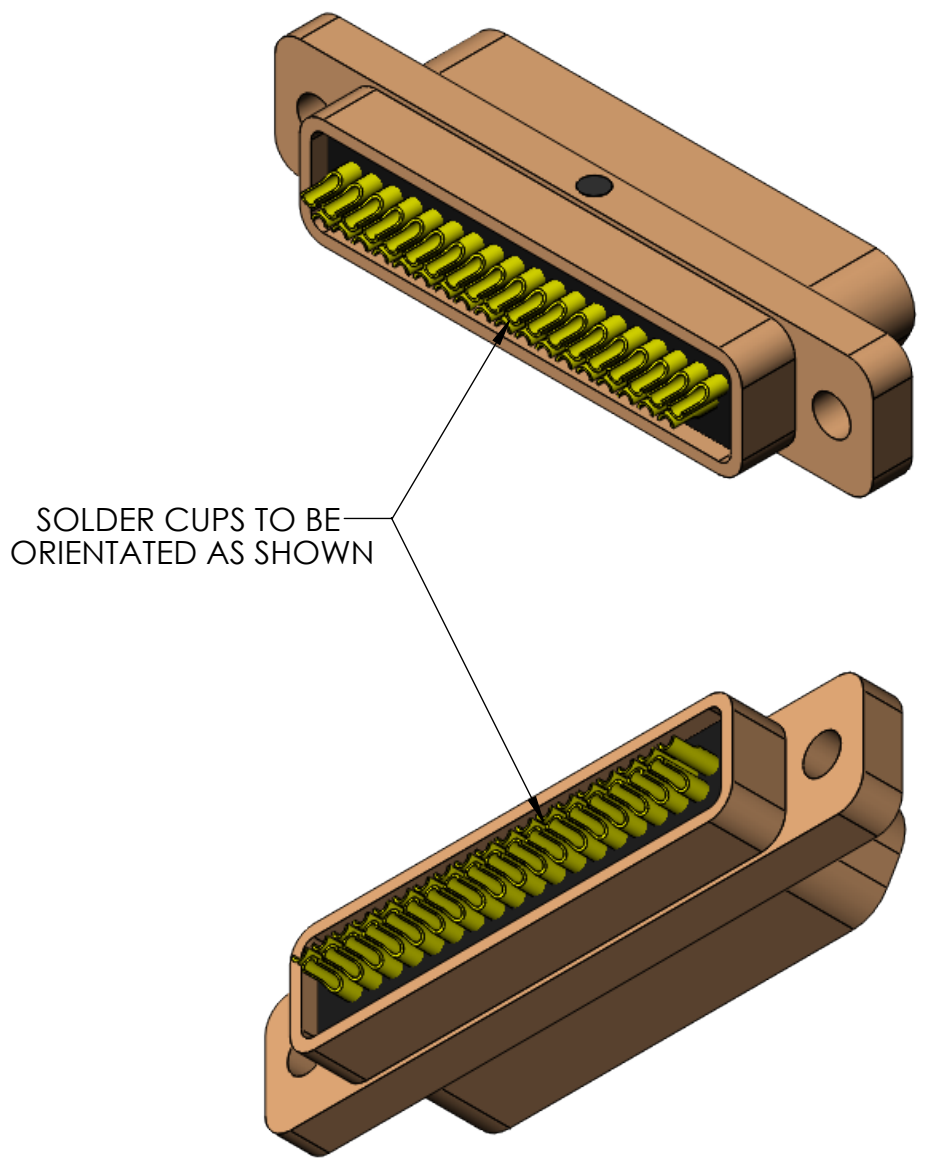
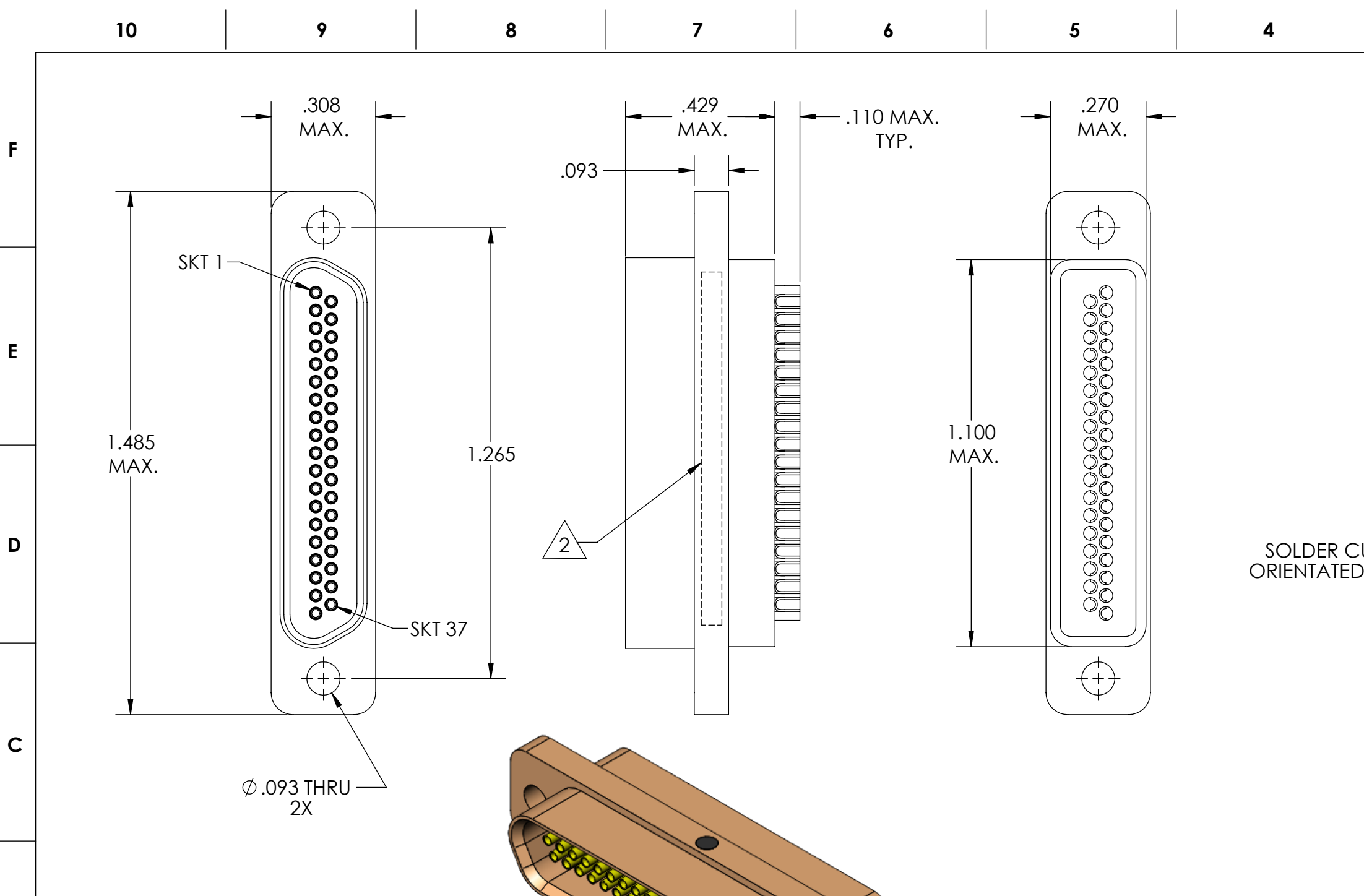

5. CONTACT HEIGHTS ARE TO BE PER QA-STD-101.
4. PERFORMANCE SPECIFICATIONS:
 CURRENT RATING: 3 AMPS MAX.
 DWV: 600 VAC
 TEMPERATURE RATING: -55°C TO 125°C
3. MATERIALS:
 SHELL: 6061-T6 ALUMINUM PER AMS-Q-Q-A200/8, CADMIUM PLATED PER AMS-QQ-P-416
 INSULATOR: PPS PER MIL-M-24519 GST-40F, COLOR: BLACK
 SOCKET SOLDERCUP CONTACTS: C314 BRONZE PER ASTM B140, GOLD PLATED PER ASTM B488
 INTERFACIAL SEAL: FLUOROSILICONE PER MIL-R-25988
2. MARKING: "UMI", DATE CODE, UMI PART NUMBER, UMI WORK ORDER NUMBER
1. CONNECTOR ASSEMBLY IS IAW MIL-DTL-83513 UNLESS OTHERWISE SPECIFIED.
- NOTES: UNLESS OTHERWISE SPECIFIED.**

| | | | | | | |
|---|---|----------------------------------|---|-----------------------------|---------------------|--|
| QUALITY SYMBOLS CRITICAL MAJOR NO SYMBOLS = MINOR DIMENSIONS | UNLESS OTHERWISE SPECIFIED: ALL DIMENSIONS ARE IN INCHES | SCALE 3:1 | DWG SIZE B | THIRD ANGLE PROJECTION | REVISE ON CAD ONLY | |
| | GENERAL TOLERANCES: 3 PLACES ±.005 2 PLACES ±.01 ANGULAR ±2° | DRAWN BY & DATE DU 2/10/20 | TITLE: MICRO-D CONNECTOR ASSEMBLY, MR37T0, CADMIUM PLATED SHELL | | | |
| | ULTI-MATE CAGE CODE 58967 | CHECKED BY & DATE DW 2/10/20 | MATERIAL: 3 | ENG PROJECT #: NONE | SHEET NO. 1 of 1 | |
| | | APPROVED BY & DATE DW 2/10/20 | PART NO. 834260000 | DRAWING NO. SD-834260000 | PART REV. - | |

CAD FILE NAME: SD-834260000.SLDDRW

THIS DRAWING CONTAINS INFORMATION THAT IS PROPRIETARY TO ULTI-MATE INCORPORATED AND SHOULD NOT BE USED WITHOUT WRITTEN PERMISSION.

