

PART REV	DWG ISSUE	DATE	ECN NO.	APPVD BY	REL BY
-	-	3/16/15	UMI5548	DW	DW

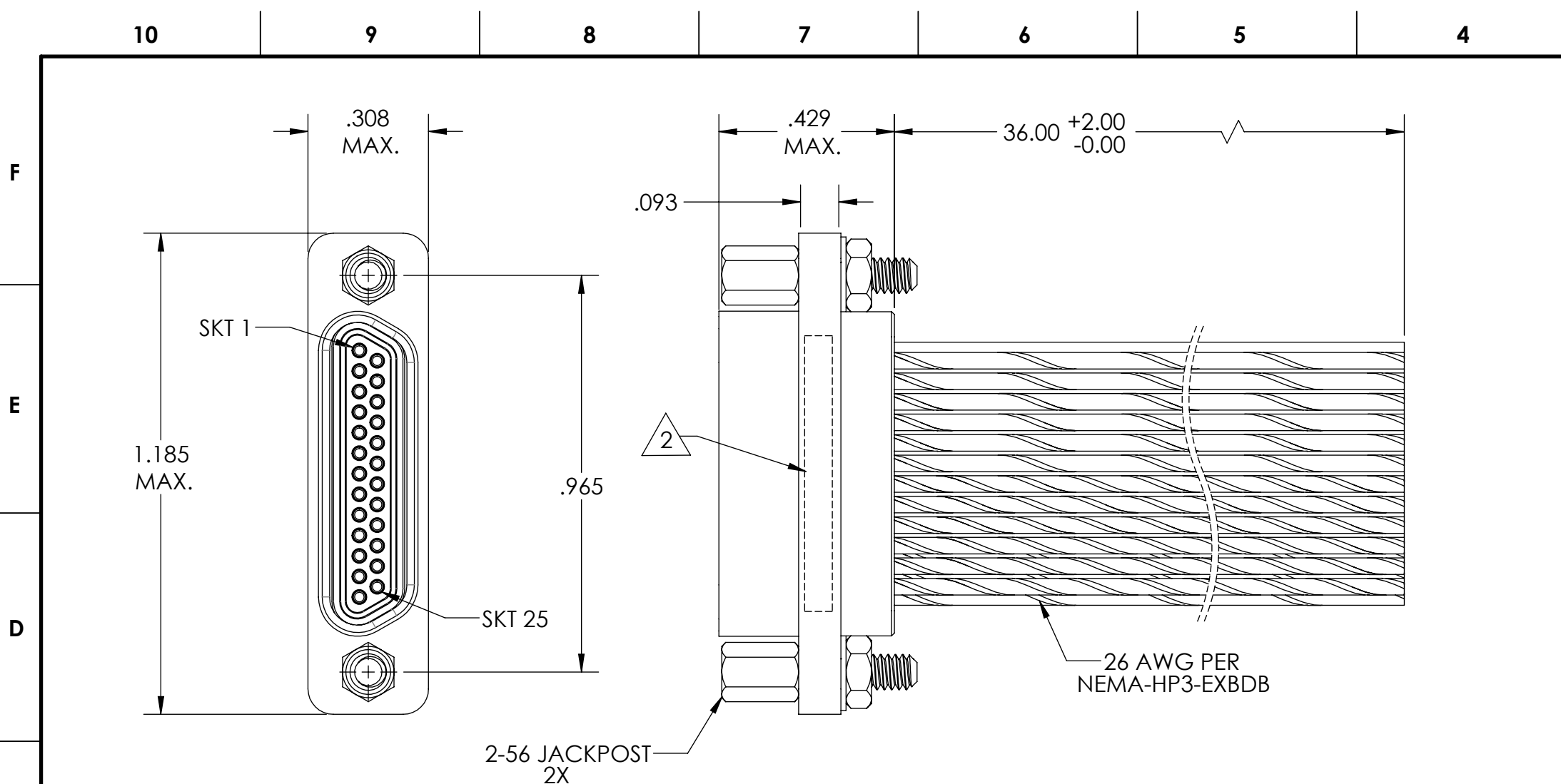

1	BLK
2	BRN
3	RED
4	ORG
5	YEL
6	GRN
7	BLU
8	VIO
9	GRY
10	WHT
11	W/BLK
12	W/BRN
13	W/RED
14	W/ORG
15	W/YEL
16	W/GRN
17	W/BLU
18	W/VIO
19	W/GRY
20	W/BLK/BRN
21	W/BLK/RED
22	W/BLK/ORG
23	W/BLK/YEL
24	W/BLK/GRN
25	W/BLK/BLU

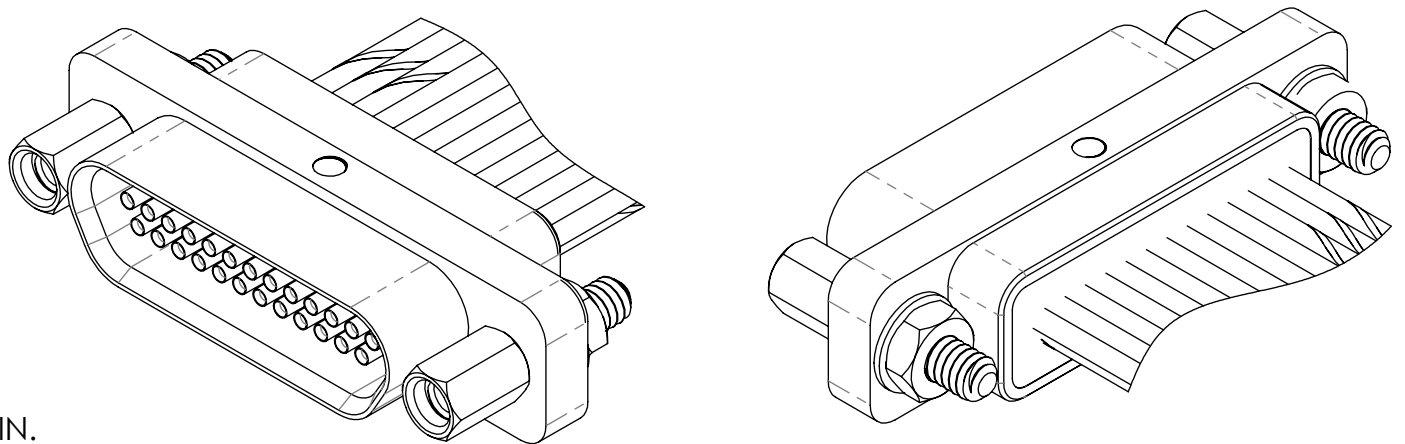

4. PERFORMANCE SPECIFICATIONS:
 CURRENT RATING: 3 AMPS MAX.
 INSULATION RESISTANCE: 5000 MEGOHMS MIN.
 DWV: 600 VAC
 TEMPERATURE RATING: 125° C

3 MATERIALS:
 SHELL: 6061-T6 ALUMINUM PER AMS-QQ-A200/8, CADMIUM PLATED PER AMS-QQ-416
 INSULATOR: PPS PER MIL-M-24519 GST-40F, COLOR: BLACK
 SOCKET CONTACT: C21000 COPPER ALLOY PER ASTM B36, GOLD PLATED PER ASTM B488
 WIRE: 26 AWG PER NEMA-HP3-EXBDB, COLOR CODE: PER MIL-STD-681
 HARDWARE: PASSIVATED STAINLESS STEEL IAW MIL-DTL-83513/5
 INTERFACIAL SEAL: FLUOROSILICONE PER MIL-R-25988

2 MARKING: "UMI", DATE CODE, UMI PART NUMBER
 1. CONNECTOR ASSEMBLY IS IAW MIL-DTL-83513 UNLESS OTHERWISE SPECIFIED.
NOTES: UNLESS OTHERWISE SPECIFIED.

QUALITY SYMBOLS CRITICAL MAJOR NO SYMBOLS = MINOR DIMENSIONS	UNLESS OTHERWISE SPECIFIED: ALL DIMENSIONS ARE IN INCHES	SCALE 3:1	DWG SIZE B	 THIRD ANGLE PROJECTION	REVISE ON CAD ONLY	
	GENERAL TOLERANCES: 3 PLACES ±.005 2 PLACES ±.01 ANGULAR ±2° ULTI-MATE CAGE CODE 58967	DRAWN BY & DATE DU 3/16/15	TITLE: MICRO-D CONNECTOR ASSEMBLY, MR25S07-26E5-36.0		MATERIAL:	
		CHECKED BY & DATE DW 3/16/15	ENG PROJECT #: NONE			
		APPROVED BY & DATE DW 3/16/15	CAD FILE NAME SD-834240537.SLDDRW	PART NO. 834240537	DRAWING NO. SD-834240537	SHEET NO. 1 of 1
THIS DRAWING CONTAINS INFORMATION THAT IS PROPRIETARY TO ULTI-MATE INCORPORATED AND SHOULD NOT BE USED WITHOUT WRITTEN PERMISSION.						