

PART REV	DWG ISSUE	DATE	ECN NO.	APPVD BY	REL BY
-	-	3/13/15	UMI5548	DW	DW

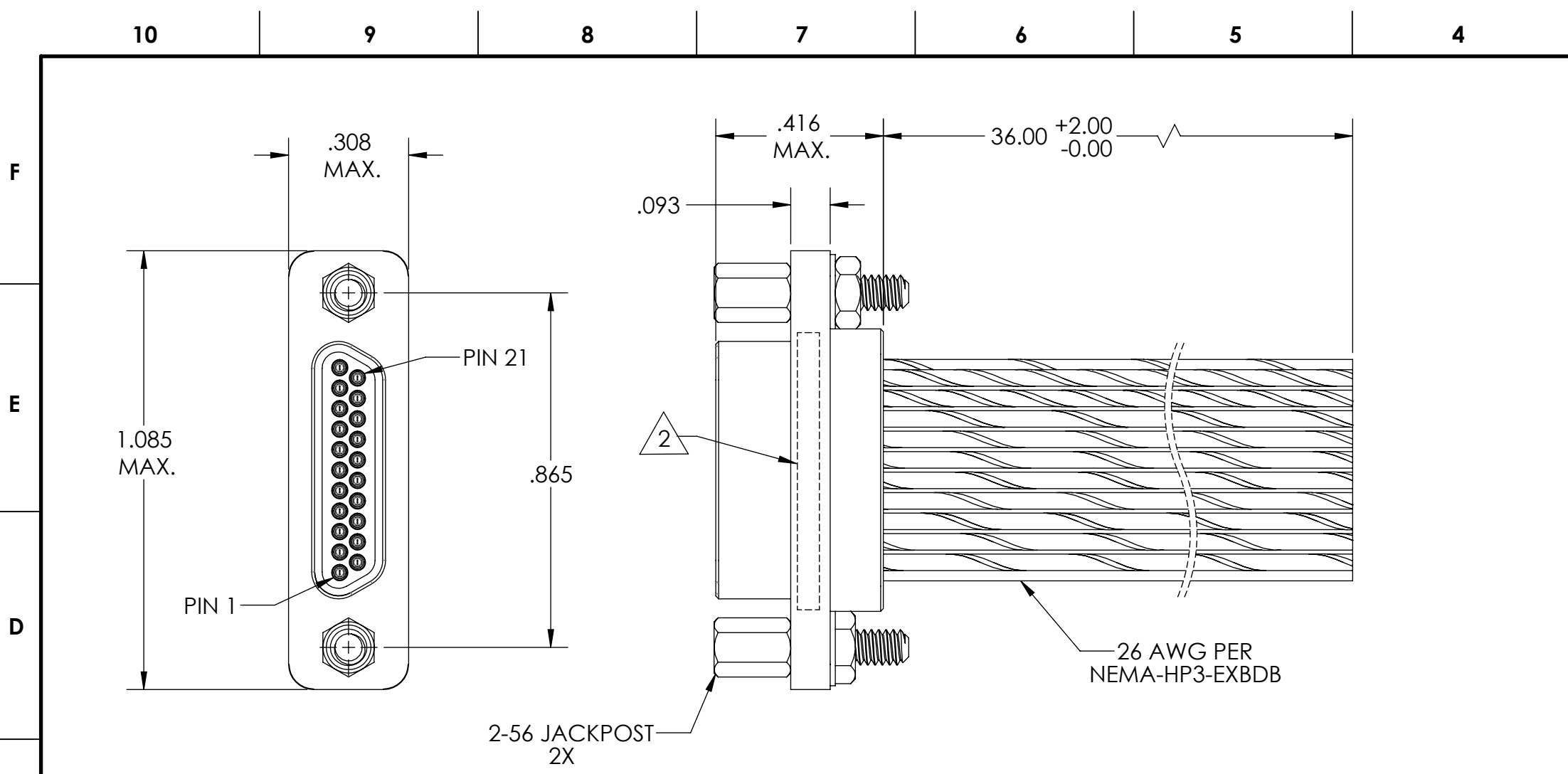

1	BLK
2	BRN
3	RED
4	ORG
5	YEL
6	GRN
7	BLU
8	VIO
9	GRY
10	WHT
11	W/BLK
12	W/BRN
13	W/RED
14	W/ORG
15	W/YEL
16	W/GRN
17	W/BLU
18	W/VIO
19	W/GRY
20	W/BLK/BRN
21	W/BLK/RED

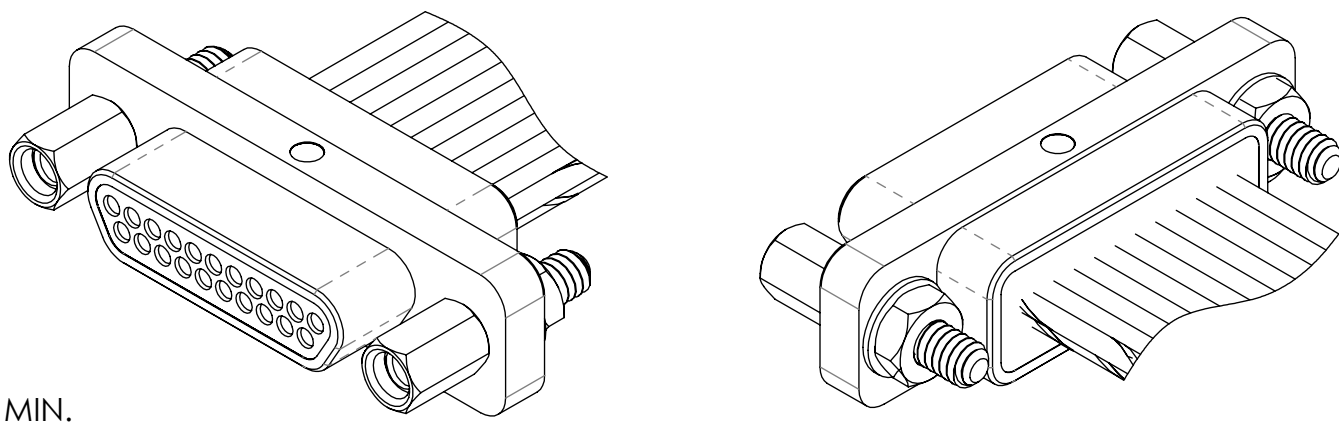

4. PERFORMANCE SPECIFICATIONS:  
 CURRENT RATING: 3 AMPS MAX.  
 INSULATION RESISTANCE: 5000 MEGOHMS MIN.  
 DWV: 600 VAC  
 TEMPERATURE RATING: 125° C

3 MATERIALS:  
 SHELL: 6061-T6 ALUMINUM PER AMS-QQ-A200/8, CADMIUM PLATED PER AMS-QQ-416  
 INSULATOR: PPS PER MIL-M-24519 GST-40F, COLOR: BLACK  
 PIN CONTACT: C17200 BERYLLIUM COPPER PER ASTM B194, GOLD PLATED PER ASTM B488  
 WIRE: 26 AWG PER NEMA-HP3-EXBDB, COLOR CODE: PER MIL-STD-681  
 HARDWARE: PASSIVATED STAINLESS STEEL IAW MIL-DTL-83513/5

2 MARKING: "UMI", DATE CODE, UMI PART NUMBER  
 1. CONNECTOR ASSEMBLY IS IAW MIL-DTL-83513 UNLESS OTHERWISE SPECIFIED.  
**NOTES: UNLESS OTHERWISE SPECIFIED.**

QUALITY SYMBOLS CRITICAL MAJOR NO SYMBOLS = MINOR DIMENSIONS	UNLESS OTHERWISE SPECIFIED: ALL DIMENSIONS ARE IN INCHES	SCALE 3:1	DWG SIZE B	THIRD ANGLE PROJECTION	REVISE ON CAD ONLY		
	GENERAL TOLERANCES: 3 PLACES ±.005 2 PLACES ±.01 ANGULAR ±2°	DRAWN BY & DATE DU 3/13/15	TITLE: MICRO-D CONNECTOR ASSEMBLY, MR21P07-26E5-36.0		MATERIAL: 3	ENG PROJECT #: NONE	
	ULTI-MATE CAGE CODE 58967	CHECKED BY & DATE DW 3/13/15	APPROVED BY & DATE DW 3/13/15	PART NO. 834130537	DRAWING NO. SD-834130537	SHEET NO. 1 of 1	PART REV. -
	THIS DRAWING CONTAINS INFORMATION THAT IS PROPRIETARY TO ULTI-MATE INCORPORATED AND SHOULD NOT BE USED WITHOUT WRITTEN PERMISSION.						