

PART DWG REV ISSUE	DATE	ECN NO.	APPD BY	REL BY
-	02/17/11	UMI4304	TPOWBART	PER

- WIRING COLOR CODE
- 1, 11, 21, 31 — BLACK
 - 2, 12, 22, 32 — BROWN
 - 3, 13, 23, 33 — RED
 - 4, 14, 24, 34 — ORANGE
 - 5, 15, 25, 35 — YELLOW
 - 6, 16, 26, 36 — GREEN
 - 7, 17, 27, 37 — BLUE
 - 8, 18, 28 — VIOLET
 - 9, 19, 29 — GRAY
 - 10, 20, 30 — WHITE

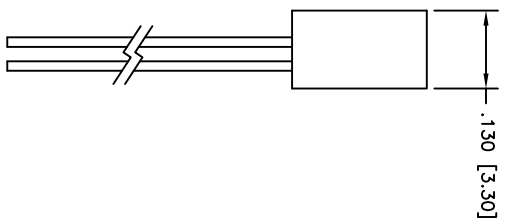
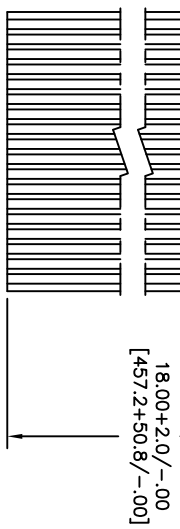
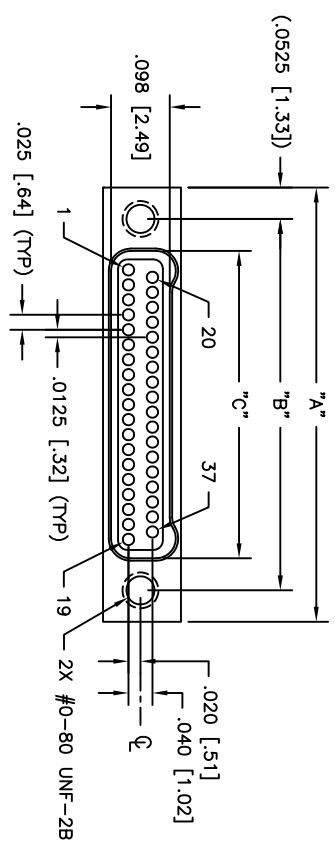

PART NO.	SIZE	"A"	"B"	"C"
833418627	9	.375 [9.52]	.270 [6.86]	.163 [4.14]
833428627	15	.450 [11.43]	.345 [8.76]	.238 [6.04]
833438627	21	.525 [13.33]	.420 [10.67]	.313 [7.95]
833448627	25	.575 [14.60]	.470 [11.94]	.363 [9.22]
833458627	31	.650 [16.51]	.545 [13.84]	.438 [11.12]
833468627	37	.725 [18.41]	.620 [15.75]	.513 [13.03]
833478627	51	.900 [22.86]	.795 [20.19]	.688 [17.47]
833488627	65	1.075 [27.30]	.970 [24.64]	.863 [21.92]

3. PERFORMANCE: MEETS OR EXCEEDS M32139 PERFORMANCE SPECIFICATIONS
 CONTACT RATING: 1 AMPERE MAXIMUM
 DMV: 250 VAC
 INSULATION RESISTANCE: 5000 MEGOHMS MINIMUM @ 100 VDC
 CONTACT RESISTANCE: 0.071 VOLT MAXIMUM DROP @ 1.0 AMPS (.071 OHMS)
 W/6.00" OF WIRE LISTED BELOW, PER MIL-DTL-32139

2. MATERIALS: SHELL AND INSULATOR: LCP (LIQUID CRYSTAL POLYMER) GLCP-30F
 CONTACT: BRASS ALLOY 735, GOLD PLATED PER ASTM B488
 LEADS: 30 AWG, NEMA HP3, TYPE ET, COLOR CODED PER MIL-DTL-681, SYSTEM 1,
 EXCEPT USING 10 SOLID REPEATING COLORS

1. MARKINGS: UMI, DATE CODE, UMI P/N AS SPACE PERMITS OTHERWISE ON BAG OR TAG
 NOTES: UNLESS OTHERWISE SPECIFIED

QUALITY SYMBOLS	UNLESS SPECIFIED, ALL DIMENSIONS IN INCHES	SCALE	DWG SIZE	THIRD ANGLE PROJECTION	REVISE ON CAD ONLY
MAJOR =	GENERAL TOLERANCES:	DRAWN BY & DATE	B		
CRITICAL C/ =	3 PLACE ±.005	CHECKED BY & DATE	03-09-10	TITLE:	NANO-D DUAL ROW CONNECTOR
SPC S/ =	2 PLACE ±.010	SEE ECN		MATERIAL:	FEMALE, SIZE XX, NPLXX-2S07-30F6-18.0
	ANGULAR ±2°	APPROVED BY & DATE			
		SEE ECN			
		CAD FILENAME	SD-833468627.DWG	PART NO.	DRAWING NO.
				SEE "TAB BLOCK"	SD-833468627
				THIS DRAWING CONTAINS INFORMATION THAT IS PROPRIETARY TO ULTI-MATE	SHEET NO.
				INCORPORATED AND SHOULD NOT BE USED WITHOUT WRITTEN PERMISSION	1 OF 1
					REV

Uti+ - Mate CASE CODE
58967

Uti+ - Mate Connector Inc.