

3			2		
PART REV	DWG ISSUE	DATE	ECN NO.	APPVD BY	REL BY
-	-	02/24/16	UMI5893	T.POMBART	PER
A	A	07/07/22	UMI8066	CB	DW
B	B	07/26/22	UMI8091	CB	DW

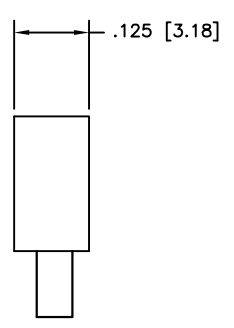
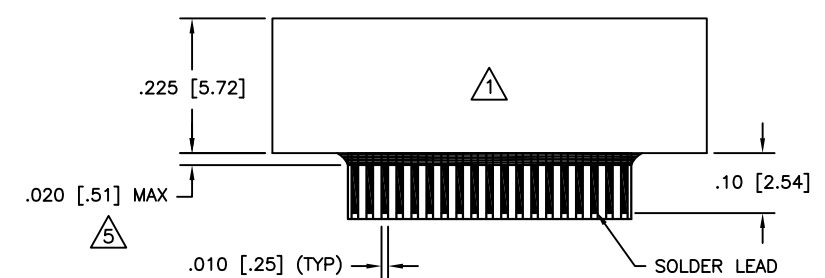
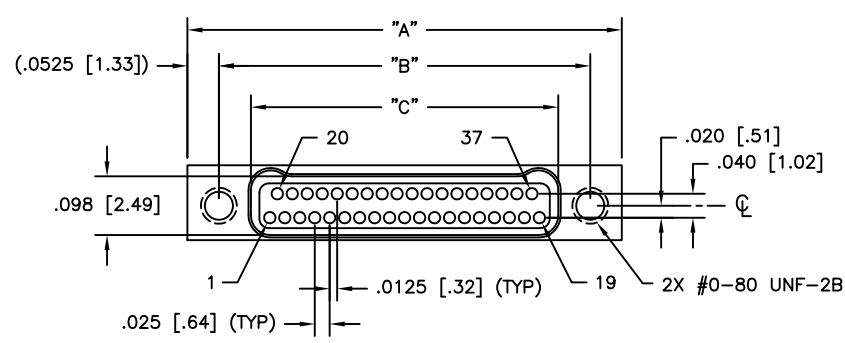

PART NO.	SIZE	"A"	"B"	"C"
833411017	9	.375 [9.52]	.270 [6.86]	.163 [4.14]
833421017	15	.450 [11.43]	.345 [8.76]	.238 [6.04]
833431017	21	.525 [13.33]	.420 [10.67]	.313 [7.95]
833441017	25	.575 [14.60]	.470 [11.94]	.363 [9.22]
833451017	31	.650 [16.51]	.545 [13.84]	.438 [11.12]
833461017	37	.725 [18.41]	.620 [15.75]	.513 [13.03]
833471017	51	.900 [22.86]	.795 [20.19]	.688 [17.47]
833481017	65	1.075 [27.30]	.970 [24.64]	.863 [21.92]

△ A LINE OF EPOXY TO BE ADDED, AS SHOWN, ON BOTH SIDES

4. PERFORMANCE: MANUFACTURED TO THE FOLLOWING M32139 PERFORMANCE SPECIFICATIONS
 CONTACT RATING: 1 AMPERE MAXIMUM AT AMBIENT TEMPERATURE
 DWV: 250 VAC
 INSULATION RESISTANCE: 5000 MEGOHMS MINIMUM @ 100 VDC
 CONTACT RESISTANCE: 0.021 VOLT MAXIMUM DROP @ 1.0 AMPS (.021 OHMS)

3. INTERMATEABILITY: INTERFACE DIMENSIONS PER MIL-DTL-32139

△ MATERIALS: SHELL: ALUMINUM 6061-T6, ELECTROLESS NICKEL PLATED PER AMS2404
 INSULATOR: LCP (LIQUID CRYSTAL POLYMER) GLCP-30F
 CONTACT: BERYLLIUM COPPER PER ASTM B194, GOLD PLATED PER ASTM B488
 LEADS: SN/PB PLATED

△ MARKINGS: UMI, UMI P/N, DATE CODE & W/O NO. AS SPACE PERMITS OTHERWISE ON BAG OR TAG

NOTES: UNLESS OTHERWISE SPECIFIED

QUALITY SYMBOLS MAJOR = CRITICAL = SPC =	UNLESS SPECIFIED: ALL DIMENSIONS IN INCHES	SCALE: 5:1	DWG SIZE: B	THIRD ANGLE PROJECTION	REVISE ON CAD ONLY
	GENERAL TOLERANCES: 3 PLACE ±.005 2 PLACE ±.010 ANGULAR ±2°	DRAWN BY & DATE UMI 03-09-10	TITLE: NANO-D DUAL ROW CONNECTOR FEMALE, SIZE XX, NMLXX-2T071-S01		
	Ultri-Mate CAGE CODE 58967	CHECKED BY & DATE SEE ECN	APPROVED BY & DATE SEE ECN	MATERIAL: △	Ultri-Mate Connector Inc.
		CAD FILENAME SD-833461017.DWG	PART NO. SEE "TAB BLOCK"	DRAWING NO. SD-833461017	SHEET NO. 1 OF 1

THIS DRAWING CONTAINS INFORMATION THAT IS PROPRIETARY TO ULTI-MATE INCORPORATED AND SHOULD NOT BE USED WITHOUT WRITTEN PERMISSION.