

WIRING COLOR CODE

- 1 — BLACK
- 2 — BROWN
- 3 — RED
- 4 — ORANGE
- 5 — YELLOW
- 6 — GREEN
- 7 — BLUE

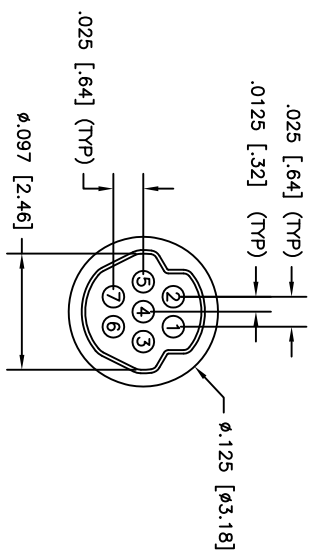
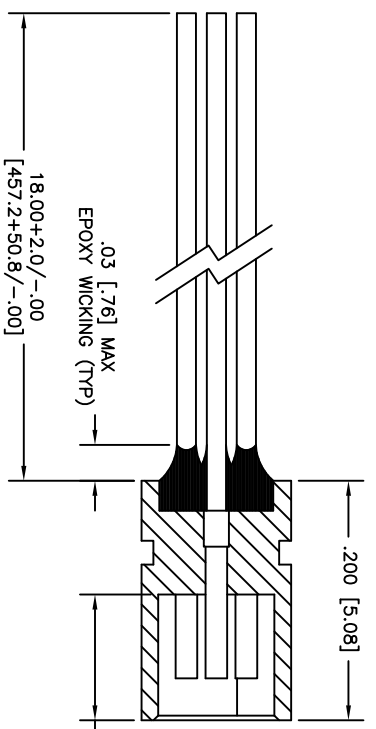

3. PERFORMANCE: MEETS OR EXCEEDS M32139 PERFORMANCE SPECIFICATIONS
 CONTACT RATING: 1 AMPERE MAXIMUM
 INSULATION RESISTANCE: 5000 MEGOHMS MINIMUM @ 100 VDC
 DMV: 250 VAC
 CONTACT RESISTANCE: 0.071 VOLT MAXIMUM DROP @ 1.0 AMPS (.071 OHMS)
 W/6.00" OF WIRE LISTED BELOW, PER MIL-DTL-32139

△ MATERIALS: INSULATOR: LCP (LIQUID CRYSTAL POLYMER) GLCP-30F
 CONTACTS: BRASS ALLOY 210, GOLD PLATED PER ASTM B488
 LEADS: 30 AWG, NEMA HP3, TYPE ET, COLOR CODED PER MIL-DTL-681, SYSTEM 1

1. MARKINGS: UMI, UMI P/N, DATE CODE & W/O NO. ON BAG OR TAG
 NOTES: UNLESS OTHERWISE SPECIFIED

PART DWG	DATE	ECN NO.	APPD BY	REL BY
REV ISSUE				
-	01/31/17	UM16217	TPOMBART	PER

QUALITY SYMBOLS	UNLESS SPECIFIED, ALL DIMENSIONS IN INCHES	SCALE	DWG SIZE	THIRD ANGLE PROJECTION	REVISE ON CAD ONLY
MAJOR =	GENERAL TOLERANCES:	10:1	B		
CRITICAL =	3 PLACE ±.005	DRAWN BY & DATE			
C/ =	2 PLACE ±.010	PER 12-23-14			
S/ =	ANGULAR ±2°	CHECKED BY & DATE			
SPC		SEE ECN			
Uti+Mate		APPROVED BY & DATE			
58967		SEE ECN			
		CAD FILENAME			
		SD-822031120.DWG			
		PART NO.			
		822031120			
		DRAWING NO.			
		SD-822031120			
		SHEET NO.			
		1 OF 1			
		PART REV			

THIS DRAWING CONTAINS INFORMATION THAT IS PROPRIETARY TO ULTI-MATE INCORPORATED AND SHOULD NOT BE USED WITHOUT WRITTEN PERMISSION