

- WIRING COLOR CODE
- 1 — BLACK
 - 2 — BROWN
 - 3 — RED
 - 4 — ORANGE
 - 5 — YELLOW

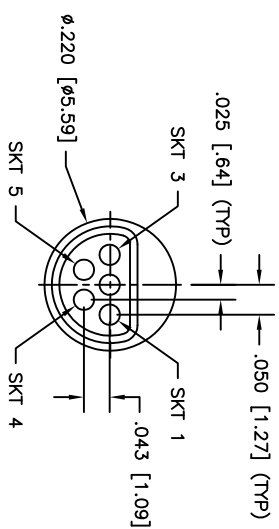
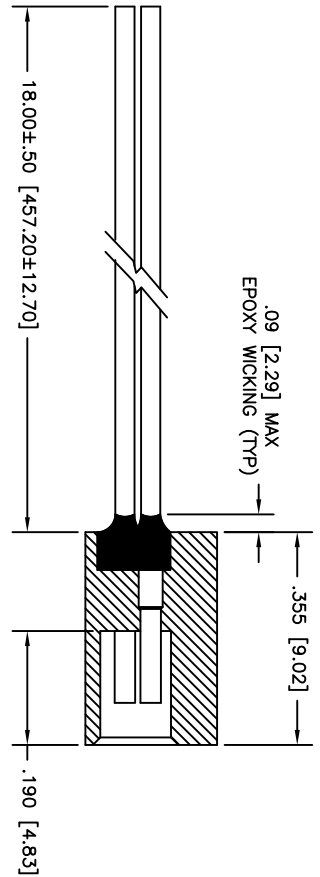

3. PERFORMANCE: MEETS OR EXCEEDS MB3513 PERFORMANCE SPECIFICATIONS
 CONTACT RATING: 3 AMPERE MAXIMUM
 INSULATION RESISTANCE: 5000 MEGOHMS MINIMUM @ 500 VDC
 CONTACT RESISTANCE: 8 MILLIOHMS MAX @ 2.5 AMPS

2. MATERIALS: INSULATOR: PPS PER MIL-M-24519 GST-40F, OR LCP (LIQUID CRYSTAL POLYMER)
 GLCP-30F COLOR: BLACK
 CONTACTS: BRASS ALLOY 210, GOLD PLATED PER ASTM B488
 LEADS: 26 AWG, MIL-W-16878/4, COLOR CODED

1. MARKINGS: UMI, UMI P/N, DATE CODE & W/O NO. ON BAG OR TAG

NOTES: UNLESS OTHERWISE SPECIFIED

QUALITY SYMBOLS	UNLESS SPECIFIED, ALL DIMENSIONS IN INCHES	SCALE	DWG SIZE	THIRD ANGLE PROJECTION	REVISE ON CAD ONLY
MAJOR =	GENERAL TOLERANCES:	10:1	B	✓	
CRITICAL C/ =	3 PLACE ±.005	DRAWN BY & DATE			
SPC =	2 PLACE ±.010	PER 02-13-13			
S =	ANGULAR ±2°	CHECKED BY & DATE			
		SEE ECN			
		APPROVED BY & DATE			
		SEE ECN			
		CAD FILENAME			
		SD-812031120.DWG			
		PART NO.			
		812031120			
		DRAWING NO.			
		SD-812031120			
		SHEET NO.			
		1 OF 1			
		REV			

PART DWG	DATE	ECN NO.	APPD BY	REL BY
REV				
ISSUE				
-	08/12/15	UM15711	TPOWBAAT	PER
A				