

10

9

8

7

6

5

4

3

2

SD-437051041

PART REV	DWG ISSUE	DATE	ECN NO.	APPVD BY	REL BY
-	-	2/25/13	UMI 4886	DW	DW
A	A	8/27/14	UMI 5403	DW	DW

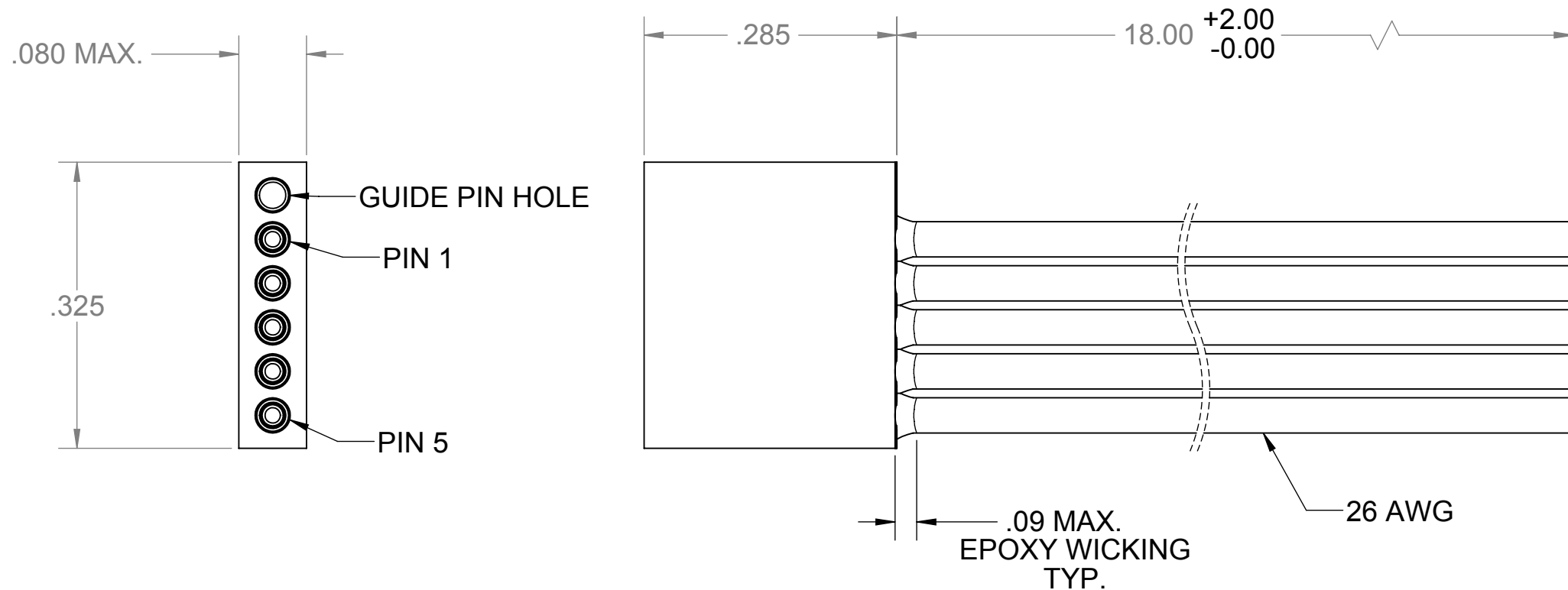

GUIDE PIN HOLE	
1	BLK
2	BRN
3	RED
4	ORG
5	YEL

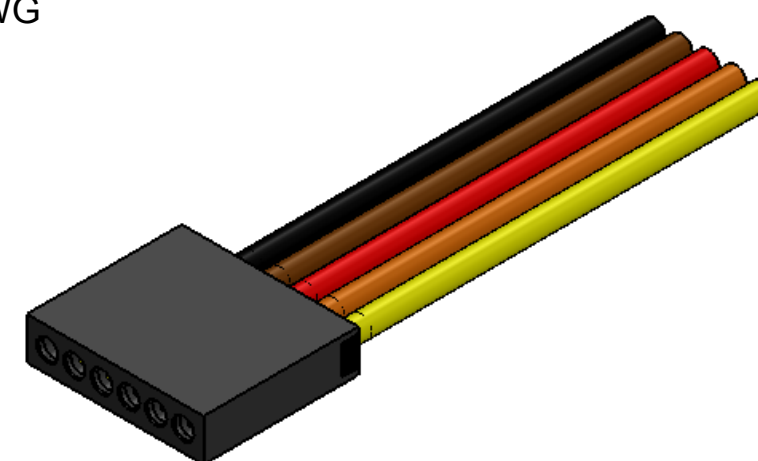

3. PERFORMANCE SPECIFICATIONS (AT AMBIENT TEMPERATURE):
 CURRENT RATING: 3 AMPS MAX.
 INSULATION RESISTANCE: 5000 MEGOHMS MIN.
 DWV: 600 VAC
 TEMPERATURE RATING: 200° C

2 MATERIALS:
 STRIP INSULATOR: PPS PER MIL-M-24519 GST-40F, COLOR: BLACK
 PIN CONTACTS: C17410 BERYLLIUM COPPER PER ASTM B768, GOLD PLATED PER ASTM B488
 WIRE: 26 AWG PER NEMA HP3-EXBDB, COLOR CODE PER MIL-STD-681.

1. MARKING: "UMI", DATE CODE, UMI PART NUMBER, (AS SPACE PERMITS).

NOTES: UNLESS OTHERWISE SPECIFIED.

QUALITY SYMBOLS MAJOR = CRITICAL = SPC =	UNLESS OTHERWISE SPECIFIED: ALL DIMENSIONS ARE IN INCHES	SCALE 6:1	DWG SIZE B	THIRD ANGLE PROJECTION	REVISE ON CAD ONLY
	GENERAL TOLERANCES: 3 PLACES ±.005 2 PLACES ±.01 ANGULAR ±2°	DRAWN BY & DATE DU 2/22/13		TITLE: MICRO STRIP CONNECTOR, SR05P1-26E6-18.0-HT, HIGH TEMP	
		CHECKED BY & DATE DW 2/22/13		MATERIAL: 2	
		APPROVED BY & DATE DW 2/22/13		PART NO. 437051041	
	ULTI-MATE CAGE CODE 58967	CAD FILE NAME SD-437051041.SLDDRW	DRAWING NO. SD-437051041	SHEET NO. 1 of 1	
THIS DRAWING CONTAINS INFORMATION THAT IS PROPRIETARY TO ULTI-MATE INCORPORATED AND SHOULD NOT BE USED WITHOUT WRITTEN PERMISSION.				PART REV. A	

