

REVISIONS

PART REV.	DWG. ISSUE	DATE	ECN NO.	APPVD. BY	REL. BY
-	-	12/17/2014	UMI5493	DW	DW

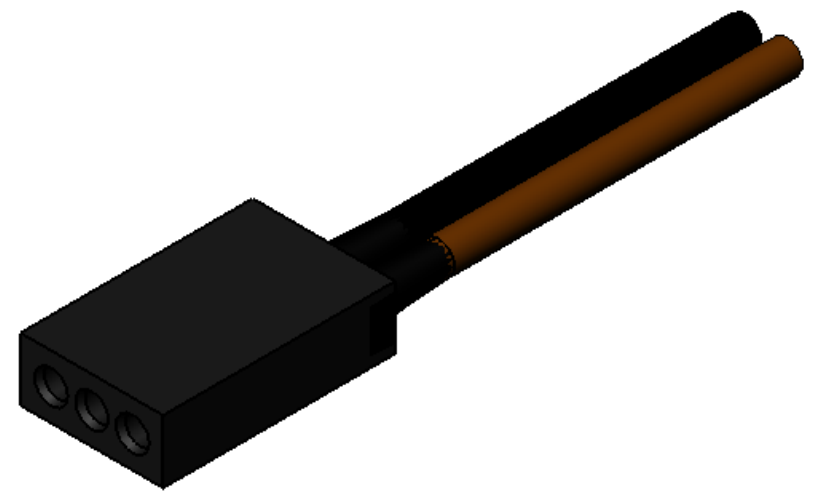
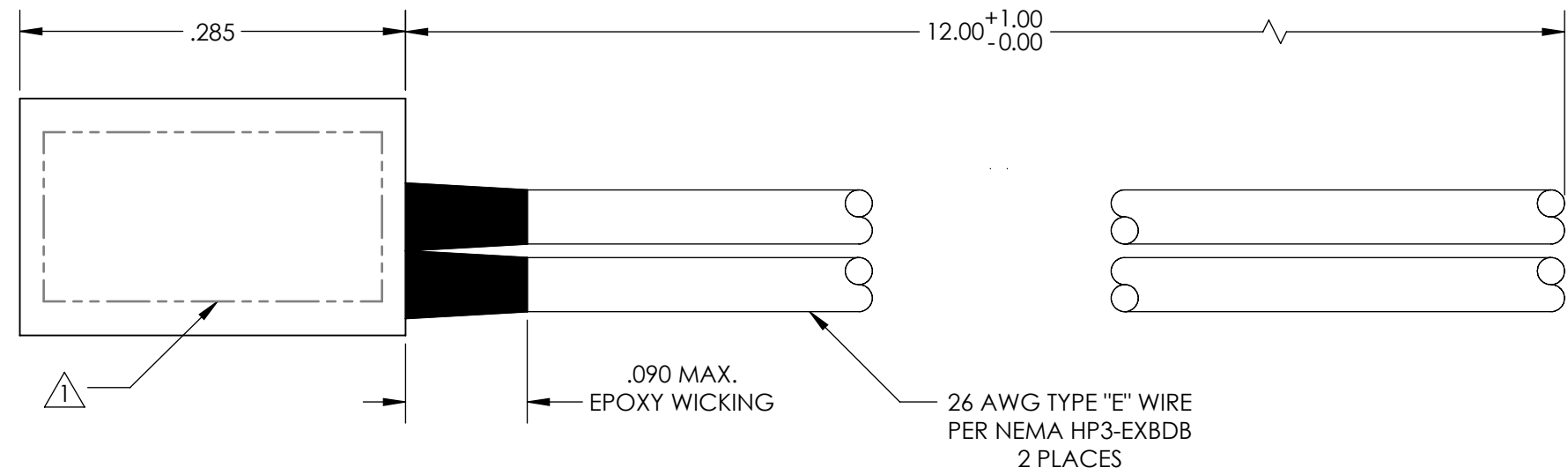
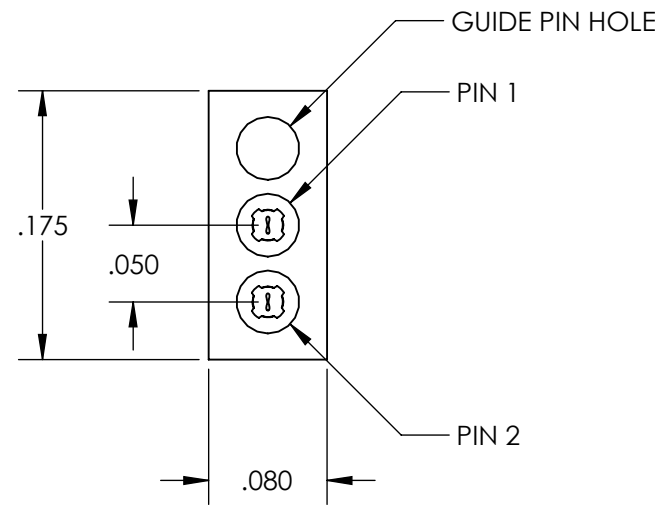

3. PERFORMANCE SPECIFICATIONS:
 CURRENT RATING: 3A MAX.
 INSULATION RESISTANCE: 5000 MΩ MIN.
 DWV: 600 VAC
 TEMPERATURE RATING: 200°C

2 MATERIALS:
 INSULATOR: PPS PER MIL-M-24519 GST-40F, COLOR: BLK
 PIN CONTACTS: C17410 BERYLLIUM COPPER PER ASTM B194, GOLD PLATED PER ASTM B488

1 MARKINGS: DATE CODE ONLY; BAG AND TAG WITH UMI, UMI PART NUMBER

NOTES: UNLESS OTHERWISE SPECIFIED

QUALITY SYMBOLS CRITICAL MAJOR NO SYMBOL = MINOR DIMENSION	UNLESS SPECIFIED: ALL DIMENSIONS IN INCHES GENERAL TOLERANCES: 3 PLACE ±.005 2 PLACE ±.01 ANGULAR ±2° ALL EXTERNAL SPECIFICATIONS REFERENCED ON THIS DRAWING SHALL BE THE LATEST REVISION IN EFFECT Ulti-Mate CAGE CODE 58967	SCALE 8:1 DWG SIZE B	 THIRD ANGLE PROJECTION	REVISE ON CAD ONLY		
	DRAWN BY & DATE JB 12/17/2014 CHECKED BY & DATE DW 12-19-14 APPROVED BY & DATE DW 12-19-14	TITLE MICRO-D WIRED STRIP CONNECTOR, PLUG, SIZE 02 W/ GUIDE PIN HOLE SR02P1-26E5-12.0-HT		MATERIAL 		ENG PROJECT #
	CAD FILENAME SD-437021351.slddrw	PART NO. 437021351	DRAWING NO. SD-437021351	SHEET NO. 1 OF 1		
	THIS DRAWING CONTAINS INFORMATION THAT IS PROPRIETARY TO ULTI-MATE INCORPORATED AND SHOULD NOT BE USED WITHOUT WRITTEN PERMISSION.			PART REV. -		