

REVISIONS

PART REV.	DWG. ISSUE	DATE	ECN NO.	APPVD. BY	REL. BY
-	-	01/20/2015	UMI5512	DW	DW

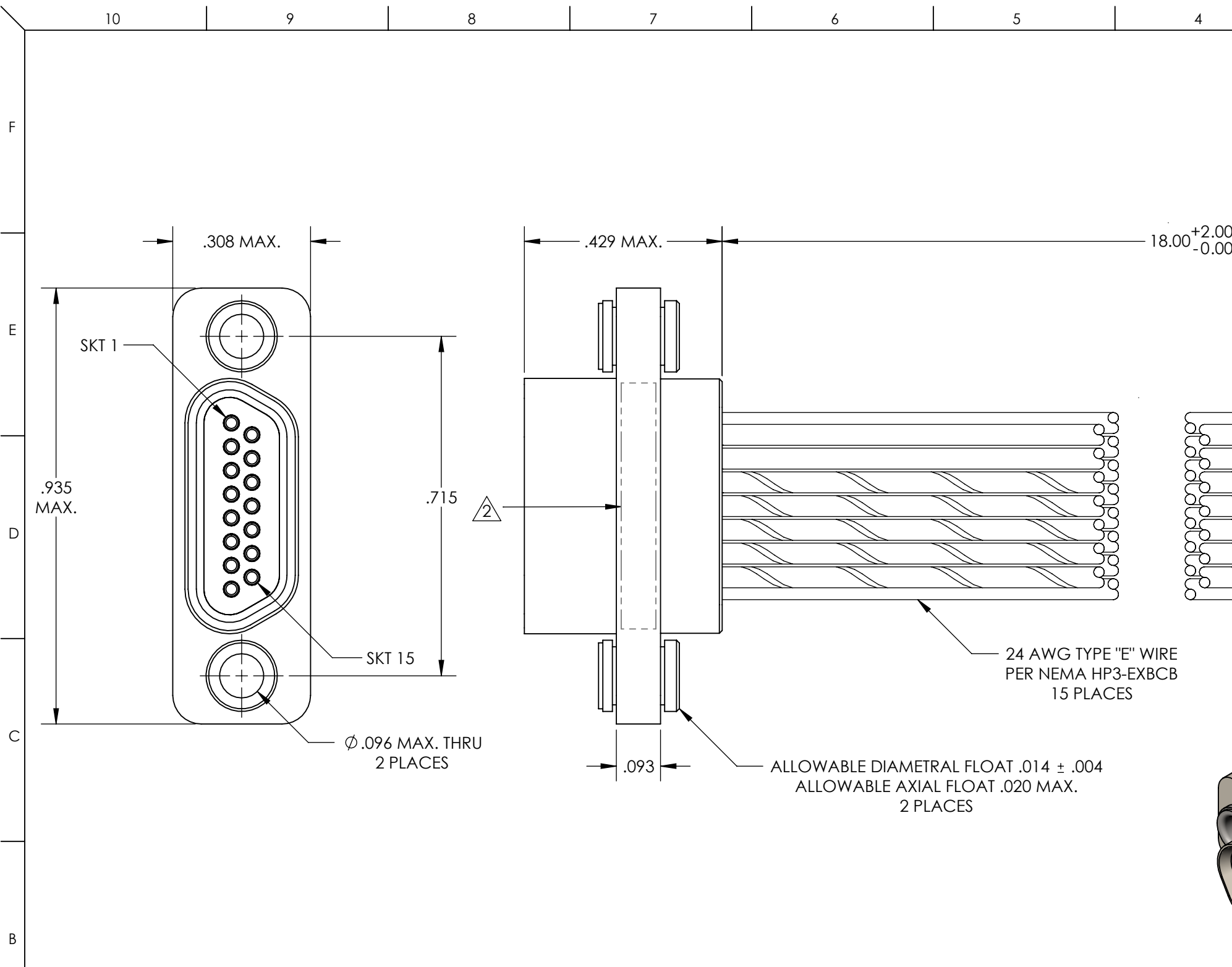

COLOR CODE

1	BLK
2	BRN
3	RED
4	ORG
5	YEL
6	GRN
7	BLU
8	VIO
9	GRY
10	WHT
11	W/BLK
12	W/BRN
13	W/RED
14	W/ORG
15	W/YEL

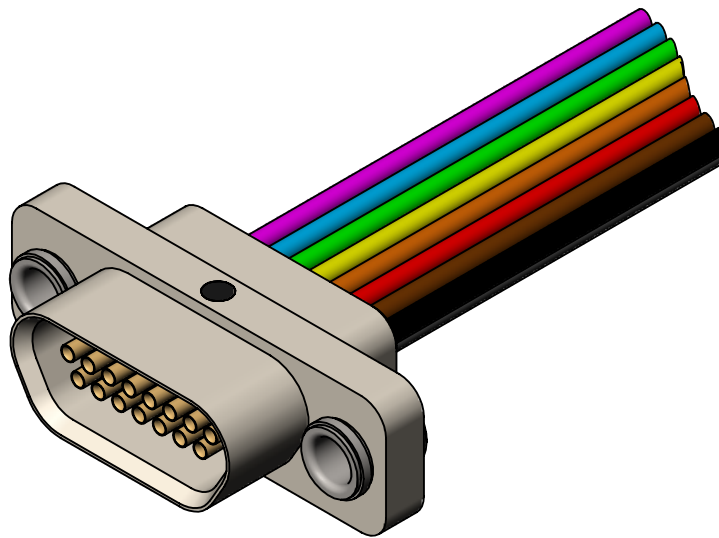

4. PERFORMANCE SPECIFICATIONS:
 CURRENT RATING: 3A MAX.
 INSULATION RESISTANCE: 5000 MΩ MIN.
 DWV: 600 VAC
 TEMPERATURE RATING: 200°C

3 MATERIALS:
 SHELL: 6061-T6 ALUMINUM PER AMS-QQ-A200/8, NICKEL PLATED PER AMS 2404
 INSULATOR: PPS PER MIL-M-24519 GST-40F, COLOR: BLK
 SOCKET CONTACTS: C21000 BRASS ALLOY PER ASTM B36, GOLD PLATED PER ASTM B488
 HARDWARE: PASSIVATED STAINLESS STEEL IAW MIL-DTL-83513/5
 INTERFACIAL SEAL: FLUOROSILICONE PER MIL-R-25988

2 MARKINGS: UMI, UMI PART NO., AND DATE CODE
 1. CONNECTOR ASSEMBLY IS IAW MIL-DTL-83513 UNLESS OTHERWISE SPECIFIED

NOTES: UNLESS OTHERWISE SPECIFIED

QUALITY SYMBOLS CRITICAL MAJOR NO SYMBOL = MINOR DIMENSION	UNLESS SPECIFIED: ALL DIMENSIONS IN INCHES GENERAL TOLERANCES: 3 PLACE ±.005 2 PLACE ±.01 ANGULAR ±2° ALL EXTERNAL SPECIFICATIONS REFERENCED ON THIS DRAWING SHALL BE THE LATEST REVISION IN EFFECT Ulti-Mate CAGE CODE 58967	SCALE 4:1 DWG SIZE B	THIRD ANGLE PROJECTION REVISE ON CAD ONLY	
	DRAWN BY & DATE JB 01/20/2015 CHECKED BY & DATE DW 1-26-15 APPROVED BY & DATE DW 1-26-15	TITLE MICRO-D WIRED CONNECTOR, RECEPTACLE, SIZE 15 W/FLOAT MOUNT BUSHINGS MR15S0-24E5-18.0-S01-F01-HT	MATERIAL 	ENG PROJECT #
	CAD FILENAME SD-434221241.slddrw	PART NO. 434221241	DRAWING NO. SD-434221241	SHEET NO. 1 OF 1
	THIS DRAWING CONTAINS INFORMATION THAT IS PROPRIETARY TO ULTI-MATE INCORPORATED AND SHOULD NOT BE USED WITHOUT WRITTEN PERMISSION.			PART REV. -