

LATCHING CIRCUIT RIGHT ANGLE CONNECTOR

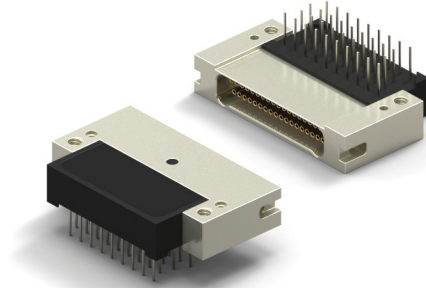







- Metal Shell Connector
- Quick Disconnect Latch Mechanism
- Plated Thru Hole .050 x .050 (Style 8)
- 1 Piece Contact
- Flat Tail Termination
- Operating Temperature -50° C to 200° C
- 9 to 37 Contacts



NANO D - PID 154

HOW TO ORDER

* Indicates preferred standard ** Consult factory for other plating options

CN	M	8	L	25	-	2	S	Ø4	1	-	SØ1	
Series	Style	Insulator	Contacts	Insulator Type	Contact Gender	Hardware	Lead Finish	Finish**	Temp Range	Mounting Option		
CN=Nano	M= Metal Shell	Style=8	L=LCP	Ø9	2= Dual Row	S=Female/Socket (Receptacle Side)	Ø4=Latch	1= Tin plated (60/40)	Blank= Cadmium	*Blank = 125C	*Blank=Threaded Mounting Holes	
				15				2=Gold plated (RoHS)		HT = 200C Supplied with Gold Plated Leads		
				21				*SØ1= Nickel			1=Solder Alignment Posts with Threaded Mounting Holes	
				25				SØ3= Black Anodize				
				31								
				37				SØ9= Stainless				

DIMENSIONS

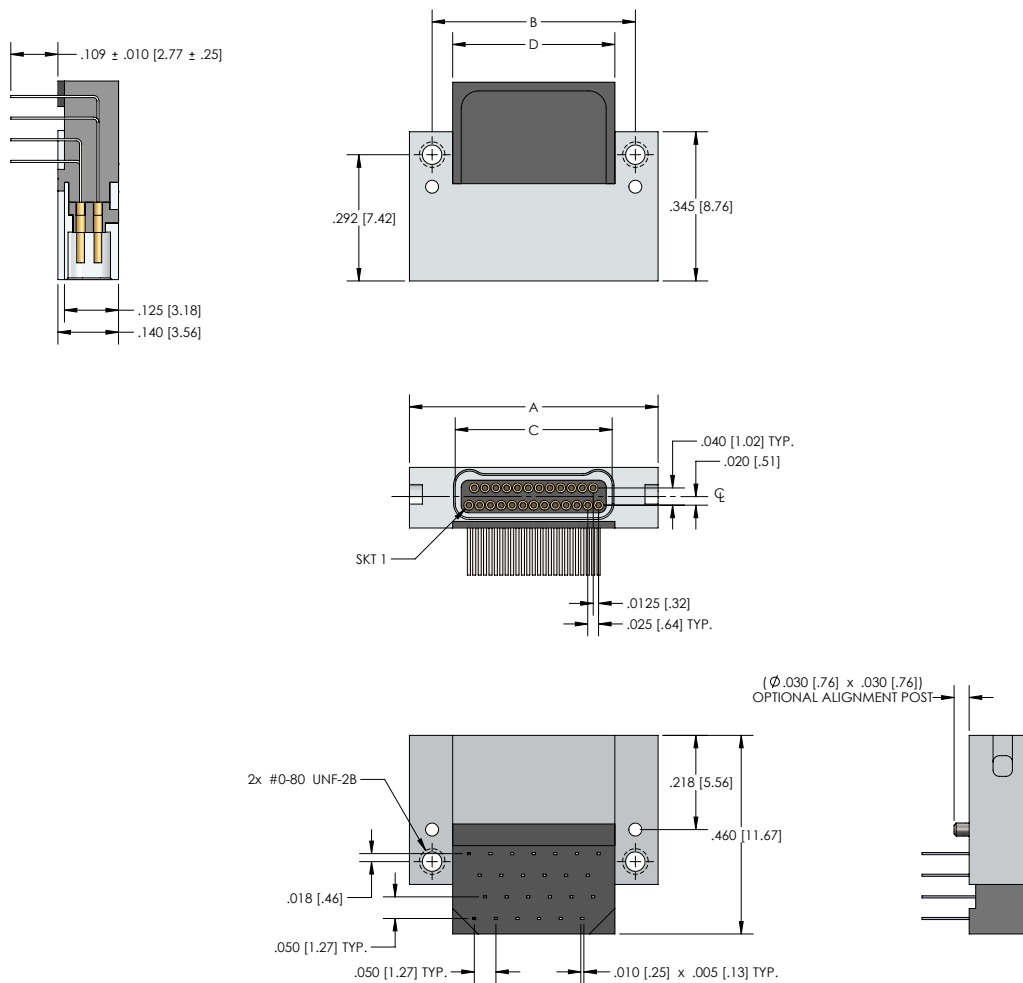

CNM8 SERIES (DUAL ROW)					
Size	A	B	Plug C	Receptacle	D
9	.375 [9.52]	.270 [6.86]	.160 [4.06]	.163 [4.14]	.175 [4.44]
15	.450 [11.43]	.345 [8.76]	.235 [5.97]	.238 [6.04]	.250 [6.35]
21	.525 [13.33]	.420 [10.67]	.310 [7.87]	.313 [7.95]	.325 [8.25]
25	.575 [14.60]	.470 [11.94]	.360 [9.14]	.363 [9.22]	.375 [9.52]
31	.650 [16.51]	.545 [13.84]	.435 [11.05]	.438 [11.12]	.450 [11.43]
37	.725 [18.41]	.620 [15.75]	.510 [12.95]	.513 [13.03]	.525 [13.33]

LATCHING CIRCUIT RIGHT ANGLE CONNECTOR PCB LAYOU FEMALE

NANO D - PID 154

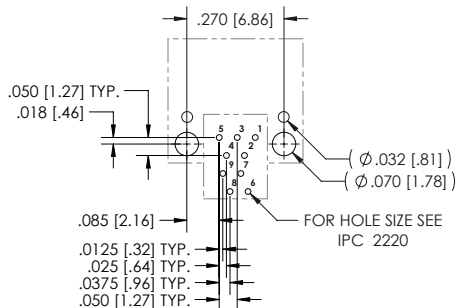
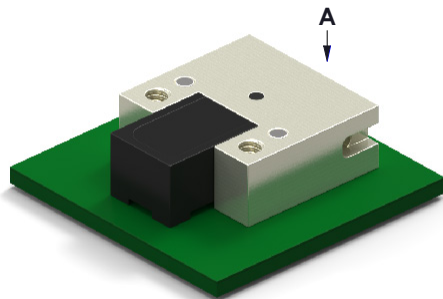

SIZE 9 - VIEW A

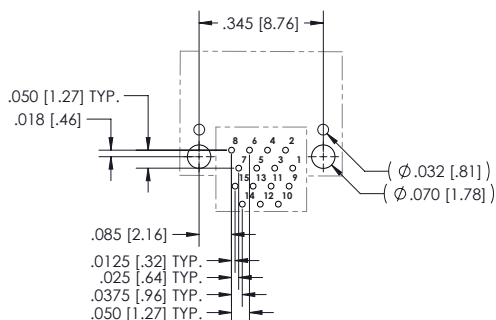

SIZE 15 - VIEW A

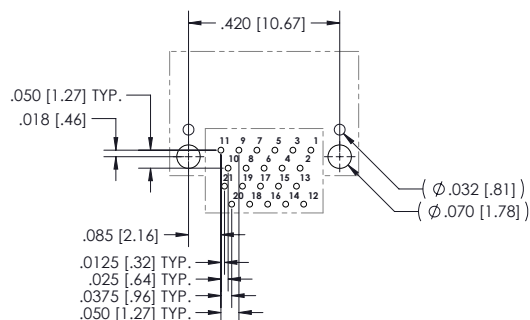

SIZE 21 - VIEW A

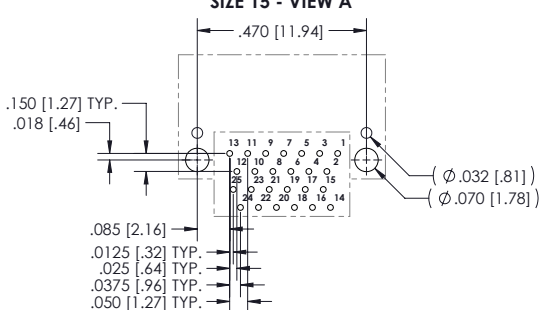

SIZE 25 - VIEW A

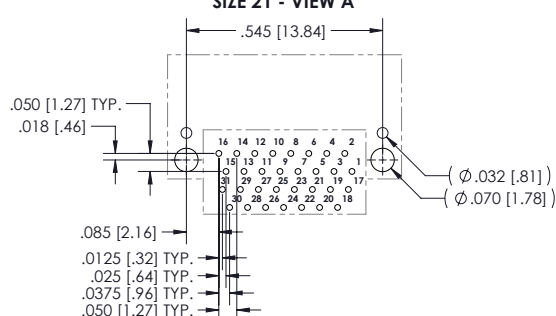

SIZE 31 - VIEW A

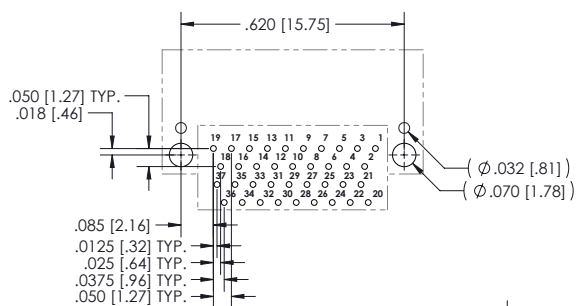

SIZE 37 - VIEW A

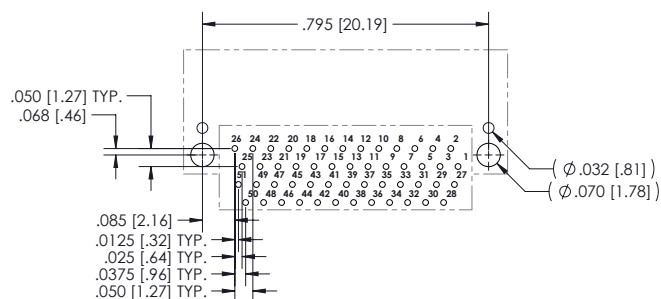

SIZE 51 - VIEW A

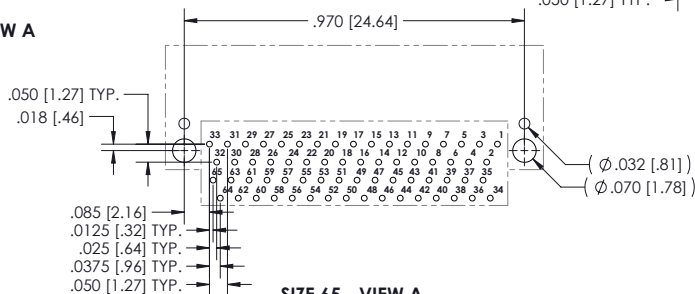

SIZE 65 - VIEW A

NANO-D LATCHING CIRCUIT METAL SHELL PERFORMANCE DATA, MATERIALS AND FINISHES

PERFORMANCE DATA

133-E	ELECTRICAL
CONTACT RESISTANCE:	0.033 mΩ max.@ 1.0 A
CURRENT RATING (SIGNAL CONTACTS):	1.0 A max.
DIELECTRIC WITHSTANDING VOLTAGE:	250 VAC at sea level , 100 VAC at 70,000 ft.
INSULATION RESISTANCE:	5,000 MΩ min.

123-M	MECHANICAL
CONTACT ENGAGING FORCE:	5 oz max. (Contact average is 2 oz.)
CONTACT SEPARATING FORCE:	0.4 oz. min.
CONNECTOR MATING FORCE:	7 oz. x number of contacts max.
CONNECTOR UNMATING FORCE:	7 oz. x number of contacts max.
VIBRATION:	No damage or interruption detected (one microsecond sensitivity) EIA-364-28 Condition IV
SHOCK:	No damage or interruption detected (one microsecond sensitivity) EIA-364-28 Condition IV
DURABILITY:	No mechanical or electrical defects after 200 matings.
SALT SPRAY:	No exposure of base metal or loss of performance after 96 hours for both Nickel and Cadmium plating

MATERIALS AND FINISHES

139 -M&F	MATERIALS AND FINISHES
Pin Contacts	BeCu alloy strip per ASTM-B-194
Socket Contacts	Sockets: BeCu per ASTM-B-194
Contact Plating	Gold plate per ASTM B488, or SAE AMS 2422
Metal Shells	Aluminum alloy per SAE-AMS-QQ-A-200/8, TYPE 6061-T6 with Electroless Nickel per SAE-AMS2404, CLASS 3 OR 4 Aluminum alloy per SAE-AMS-QQ-A-200/8, TYPE 6061-T6 with Cadmium Plating SAE-AMS-QQ-P-416, TYPE II, CLASS 1 Aluminum alloy per ALLOY PER SAE-AMS-QQ-A-200/8, TYPE 6061-T6 with Black Anodize Plating per MIL-A-8625, TYPE III, CLASS 2 Stainless Steel per ASTM A582
Molded Full Metal Housing/ Lead Organizer	LCP (Liquid Crystal Polymer) GLCP-30F or PPS per MIL-M-24519 GST-40F
Alignment Post	Corrosion resistant steel per ASTM A 582/A582 or ASTM A 581/A581M, Passivated per SAE AMS-2700